

BAY CRANE

www.baycrane.com

65 ton



Tadano ATF 650
Load Charts



TADANO

ATF-650XL

65 Ton Capacity (60 Metric Tons)

HYDRAULIC ALL TERRAIN CRANE

DIMENSIONS

() : mm

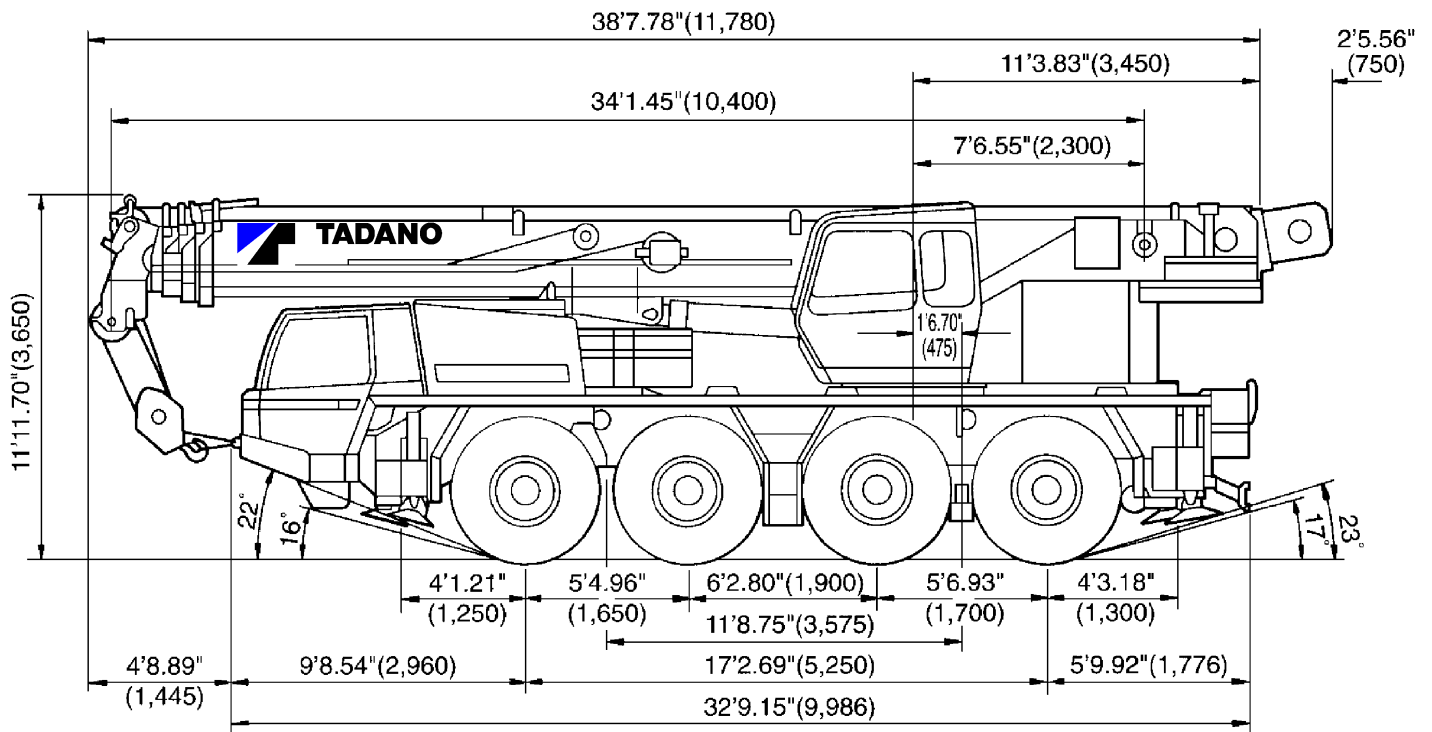

TURNING RADIUS

Steering	Front wheel (8x4)	All wheel (8x8)
Carrier inside	19.68 ft (6.0m)	9.84 ft (3.0m)
Over carrier	36.75 ft (11.2m)	26.90 ft (8.2m)
Over boom	38.06 ft (11.6m)	28.87 ft (8.8m)
Over boom extension	40.03 ft (12.2m)	30.18 ft (9.2m)
Wheel truck radius	31.17 ft (9.5m)	21.00 ft (6.4m)

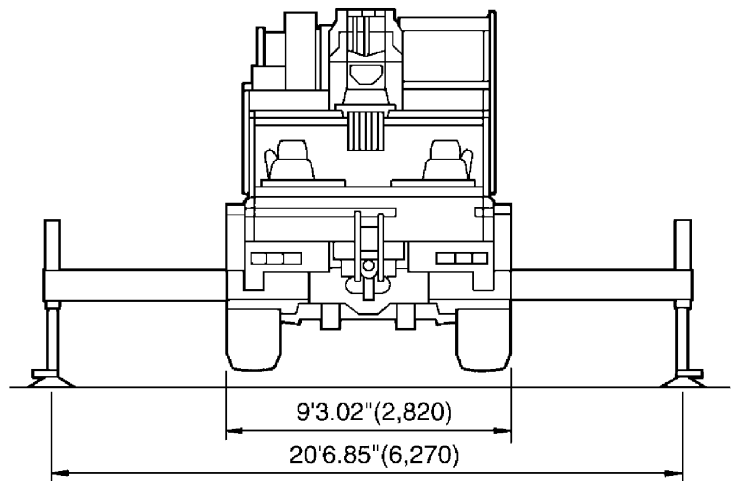

Note : Dimension is with 20.5R25 Tires.

Specifications are subject to change without notice.

1. CRANE CARRIER

1.1 FRAME

FAUN purpose built, 4 axle, box-type, torsion resistant, welded construction made of high tensile steel with integrated outrigger housings. Equipped with front and rear fenders, front and rear towing and tie-down lugs and towing connections and access ladders.

1.2 OUTRIGGERS

Four point, fully hydraulic, horizontal and vertical motions controlled by electro-magnetic valves. Push button controls on both sides of the carrier with level gauges and controlled from superstructure cab. Vertical cylinders with integral holding valves. Metallic floats can be stored on vertical cylinders or on carrier for road travel.

Outrigger base: length 25.59 ft, width 20.57 ft
(mid. extension 15.22 ft)

1.3 CARRIER ENGINE

Mercedes Benz 6 cylinder water-cooled diesel engine, model OM 501 LA (EURO 2), with hydrostatically driven fan and thermostatically controlled cooler.

Displacement 732.24 in³, Rating 348.7 hp at 1,800 rpm:
Torque 1276 ft-lbs at 1,080 rpm.

1.4 CLUTCH

Single plate, dry-type.

1.5 TRANSMISSION

ZF 16S151, mechanical 16 speed transmission with "Easyshift-2" shifting. Sixteen forward and two reverse gears.
Gear ratios: Forward: 13.80 / 11.55 / 9.59 / 8.02 / 6.81 / 5.70 / 4.58 / 3.84 / 3.01 / 2.52 / 2.09 / 1.75 / 1.49 / 1.24 / 1.00 / 0.84
Reverse: 13.17 / 11.03

1.6 DRIVE

8x6 :

for on-road: 3rd and 4th axle are driven

for off-road: 2nd, 3rd and 4th axle are driven

1.7 AXLES

1st axle : steered, non-driven

2nd axle steered, driven with transverse differential lock,

3rd axle : steered, driven with transverse differential lock,
reduction : 7.29, with integrated transfer case with
reduction : 0.81

4th axle : steered, driven with transverse differential lock,
reduction : 7.29

All steering knuckle bearings designed for minimum maintenance (yearly inspection).

1.8 SUSPENSION

Hydro-pneumatic, lockable with level adjustment. All axles have longitudinal and transverse trailing arms. With leveling adjustment and locked cylinders, the chassis can be tilted laterally and longitudinally by push buttons in the carrier cab which adjust the stroke of each individual suspension cylinder. All bearings are designed for minimum maintenance (yearly inspection).

Cylinder stroke: Compress/Rebound : ±3.94 in.

1.9 BRAKE SYSTEM

Service : Dual circuit compressed air system with air dryer.

Parking : Spring loaded type, acting on 2nd, 3rd and 4th axle.

Auxiliary : Engine exhaust brake and constant throttle engine brake system.

1.10 WHEELS

(8) 17.00-25 steel disc wheels with (8) 20.5R25 on / off-road profile tires and mud flaps.

1.11 STEERING SYSTEM

ZF-Servo-com-dual circuit hydraulic steering, mechanical steering of two front axles with hydraulic booster and transmission-mounted emergency steering pump.

Rear axle steering mechanically locked in "centered" position. At slow speeds, rear axles can also be hydraulically steered independently from the front axles. All bearings are designed for minimum maintenance (yearly inspection).

Hydro-static steering with electrical controls, two front axle by a lever and the rear axles by a push button for all-wheel, co-coordinated and crab steer.

1.12 POWER TRAIN

Axles, suspension cylinders and drive-shafts with geared flanges virtually maintenance-free.

1.13 FUEL TANK CAPACITY

79 gal. filler cap lockable.

1.14 CARRIER CAB

Two man full width cab of composite structure (steel sheet metal and fiber glass), windshield of laminated safety glass with windshield wiper and washer, sliding side windows of hardened glass. Driver and co-driver seats adjustable and air-suspended with integrated 3 point safety belts and headrests. 2 rear-view mirrors (electrically adjustable), 1 wide angle mirror and additional curb mirror, all mirrors heated, Radio with cassette and connections for wireless. Engine dependent warm-water heater with defroster nozzles for windshield and cab floor.

Instrumentation includes speedometer, odometer, tachograph, rpm counter with hour meter, fuel level gauge, air pressure gauge and engine warning lamp.

1.15 ELECTRICAL SYSTEM

24 volt DC system with 80 ampere 3-phase generator, and 2 batteries each 12 volt 170 Ah.

Front lighting includes 2 main head lights, 2 high beam lights, 2 fog lights, 2 directional indicators and 2 parking lights.

Rear lighting includes 2 rear combi panels each with directional indicator, parking light, brake light, fog light, reversing light and license plate light.

Side lighting includes 2 front directional indicators and reflectors on carrier.

Other equipment includes hazard warning light system, cab light, instrument panel light, signal horn and amber rotating beacon on cab roof.

Lighting according to EEC regulations.

1.16 TOOLS AND ACCESSORIES

Special tool set, tire-inflation kit, warning triangle, hazard flashing lamp, fire extinguisher and first aid kit.

1.17 PAINTING

3 color painting

2. SUPERSTRUCTURE

1.18 DIMENSIONS

Overall width : 9.25 ft with tires 20.5R25
 Overall height : 11.97 ft with tires 20.5R25
 In travel condition, the overall height can be adjusted ± 3.94 in.
 Overall length : 38.65 ft
 Carrier length : 32.18 ft
 Wheel base : 5.41 ft + 6.23 ft + 5.58 ft
 Tail swing : 11.32 ft

1.19 TRAVEL PERFORMANCE (according to DIN 70020)

Max. travel speed : 49.7 mph
 Min. travel speed in 1st gear at 800 rpm : 1.5 mph
 Max. gradeability : 37.6 %
 Acceleration from 0 to 31 mph : 28 sec.

Tires 20.5R25, Total GVW 118,500 lbs		
Gear	Travel speeds (mph) * max. engine revs	Gradeability (%)
1st	3.7	37.6
2nd	4.5	30.9
3rd	5.4	25.2
4th	6.5	20.9
5th	7.6	17.6
6th	9.1	14.7
7th	11.2	11.8
8th	13.4	9.8
9th	17.1	7.7
10th	20.5	6.4
11th	24.7	5.3
12th	29.5	4.4
13th	34.6	3.7
14th	41.6	3.0
15th	49.7	2.4
16th	49.7	1.9
1st reverse	4.2	32.9
2nd reverse	5.0	27.1

The gradeability is based on theoretical values and depends on ground conditions and the coefficient of friction.

1.20 CARRIER OPTIONAL EQUIPMENT

1. Towing coupling (D value 9.5 t) with light and brake connection
2. 14.00R25 on/off road profile tires-overall width 8' 4.4"
16.00R25 on/off road profile tires-overall width 8' 8.4"
3. Spare wheel and tire
4. Spare wheel bracket (not in combination with tool box)
5. Tool / tackle box at rear (not in combination with spare wheel bracket)
6. 8 x 4 drive
7. Eddy current brake (retarder)

2.1 SUPERSTRUCTURE FRAME

Torsion - resistant, all-welded structure of high tensile steel. Connected to carrier by a single-row ball bearing slewing ring with external gearing providing 360° continuous rotation.

2.2 CRANE ENGINE

Mercedes Benz 4 cylinder water-cooled diesel engine, model OM 904 LA (EURO 2), with 120.7 hp at 2,300 rpm. Stepless control of engine rpm by foot pedal. Engine pre-heat system. Fuel tank capacity : 52.8 gal

2.3 HYDRAULIC SYSTEM

Three circuit diesel hydraulic system with 1 axial piston variable displacement (hydraulically controlled) double pump with cumulative control for telescoping, derricking and hoisting plus 1 double gear pump for swing and pilot controls. Hydraulic oil cooler.

2.4 HYDRAULIC CONTROLS

2 joy-stick levers with hydraulically controlled 4 three-way valves for independent simultaneous operation of all crane motions with stepless speed control.

2.5 TELESCOPIC BOOM

Five section box type construction of high tensile steel, consisting of 1 base section and 4 telescopic sections. The boom is extended by means of 1 double acting single stage and 1 double acting two stage hydraulic cylinders with integrated holding valves and a rope-crowd extension system. Telescopic sections 1, 2 and 3 + 4 can be telescoped independently of each other (telescope sections 3 and 4 synchronously). All telescope sections extendable under partial load.

Total retracted length : 34.1 ft
 Total extended length : 131.9 ft
 Max. sheave height : 141 ft
 Telescoping speed out : 180 sec. normal speed /
 90 sec. high speed

2.6 TELESCOPIC BOOM EXTENSION

Swing around lattice type boom extension 29.5 ft - 52.5 ft long, offset 5° / 17° / 30°, consisting of a 29.5 ft lattice type base section and a 23 ft long box type extension which stores inside the base section. Equipped with anti-two block system.

2.7 AUXILIARY LIFTING SHEAVE (SINGLE TOP)

Single sheave mounted to main boom head for single line operation (stowable). Equipped with anti-two block system.

2.8 BOOM HOIST

1 double acting hydraulic cylinder with integral holding valve.
 Boom elevation : -2° to +82°
 Boom elevation speed : 66 sec. normal speed /
 33 sec. high speed (only derricking up)

2.9 MAIN WINCH

Axial piston constant displacement motor, grooved hoist drum, integral planetary gear, automatic hydraulically controlled spring-loaded multiple disc brake and integral free wheeling (no sagging of load by hoisting). Winch drive assembly connected to open hydraulic system. Wire rope with "Superstop" easy reeving system. Lower limit switch and drum turn indicator.

Drum diameter : 15.75 in
Rope diameter : 0.63 in
Rope length : 590 ft
Max. line pull 3rd layer : 10,000 lbs
Max. line speed 3rd layer : 213 ft/min normal / 426 ft/min high

2.10 AUXILIARY WINCH

Axial piston constant displacement motor, grooved hoist drum, integral planetary gear, automatic hydraulically controlled spring-loaded multiple disc brake and integral free wheeling (no sagging of load by hoisting). Winch drive assembly connected to open hydraulic system. Wire rope with "Superstop" easy reeving system. Lower limit switch and drum turn indicator.

Drum diameter : 15.75 in
Rope diameter : 0.63 in
Rope length : 459 ft
Max. line pull 3rd layer : 10,000 lbs
Max. line speed 3rd layer : 213 ft/min

2.11 SLEWING GEAR

Constant displacement motor with three stage planetary gear, a foot actuated service brake and a parking brake. Slewing speed infinitely variable: 0 - 2 rpm

2.12 COUNTERWEIGHT

Total 14.55 tons, consisting of 9.8 tons standard counterweight and 4.75 tons additional counterweight, divisible, assembled and disassembled by hydraulic cylinders controlled from crane cab.
Tail swing : 11.32 ft

2.13 SUPERSTRUCTURE CAB

Spacious all-steel comfortable panoramic cab with sliding door and extra-large tinted glass windows, folding-out front window with windshield washer and wiper, fixed cab roof window with armoured glass and washer/wiper, sun visor, cab light, adjustable hydraulically cushioned seat with headrest, signal horn, radio with cassette, and connection for wireless (12 volt).

Engine dependent warm-water heater with defroster nozzles for windshield and cab floor, plus additional diesel crane cab heater.

Ergonomically positioned control elements and instrumentation for crane operation including fuel level gauge, engine cooling water temperature, hour meter and combined engine warning lamp.

Travel controls for steering and driving in 1st forward and reverse gear only.

Outtrigger controls and level from superstructure cab.

2.14 ELECTRICAL SYSTEM

24 volt system with 80 A 3-phase alternator, 2 batteries each 12 V and 110 Ah, 1 rotating beacon on right-hand side of main winch, 2 working lights on cab front flap, 1 working light on boom base section and 2 side lights on boom head.

2.15 SAFETY DEVICES

Electronic load moment device (PAT DS350 GC) with interpolation and automatic overload shut-off, hoist limit switch with shut-off, overload warning and load moment gauge. Digital display of boom angle, boom length, sheave height, working radius, hook load and further information. Safety valves against pipe and hose rupture, holding valves on hydraulic cylinders.

2.16 SUPERSTRUCTURE EQUIPMENT

6.6 ton (13,228 lbs) headache ball
35.3 ton (70,547 lbs) hook block, 3 sheaves, single horn hook

ATF-650XL WORKING RANGE CHART

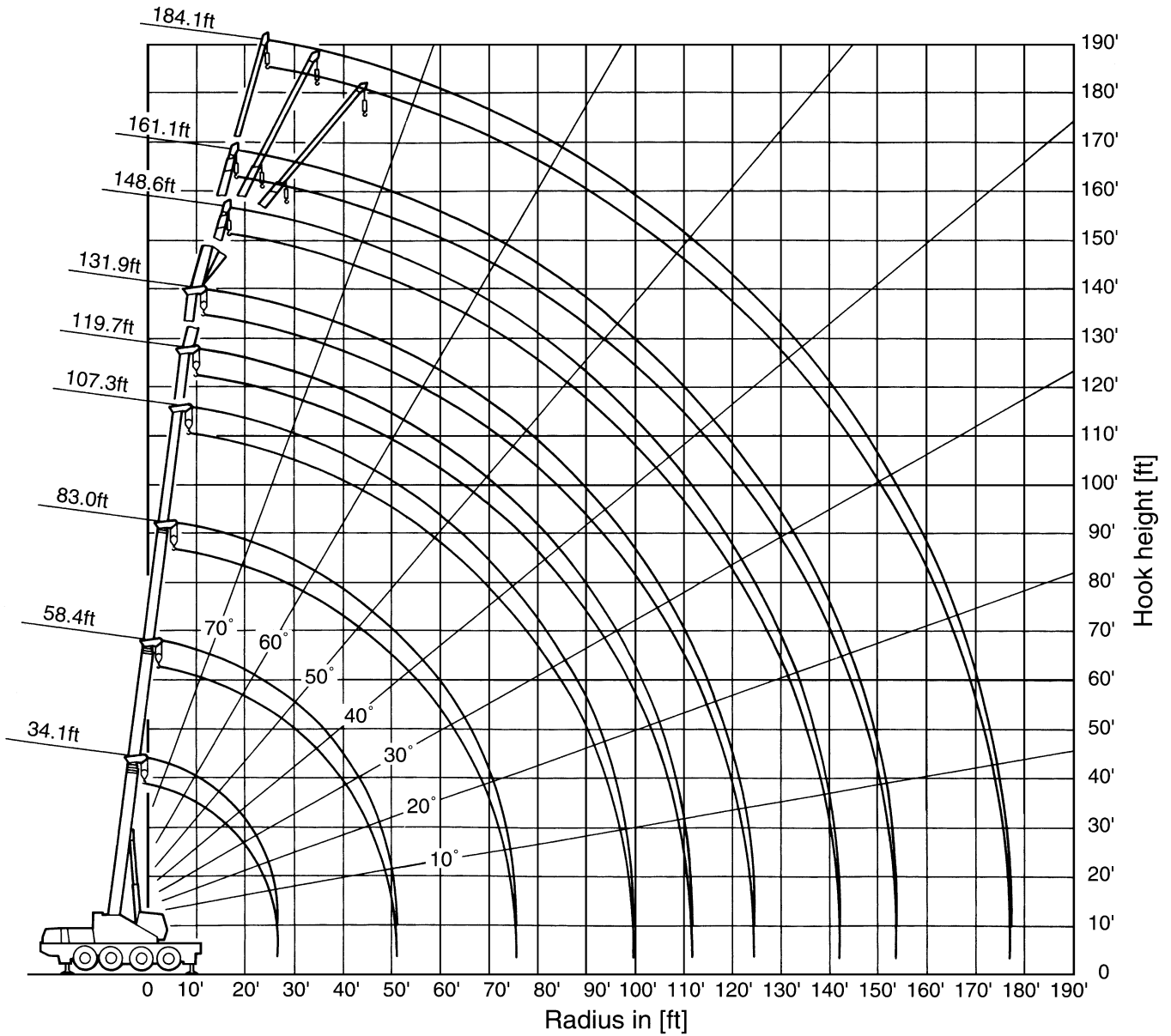

NOTE: Boom and jib geometry shown are for unloaded condition and machine standing level on firm supporting surface. Boom deflection and subsequent radius and boom angle change must be accounted for when applying load to hook.

ATF-650XL TADANO-Load rating chart

Counterweight 29,100 lbs

Working Radius (ft)	Lifting capacities in 1,000 lbs according per SAE J765 on telescopic boom On outriggers, 360° working area Outrigger base 20.57 ft														Working Radius (ft)									
	Boom length (ft)																							
	34.1		58.5		58.5		58.5		82.9		82.9		82.9			107.3		107.3		119.6		131.8		
	°	L	°	L	°	L	°	L	°	L	°	L	°	L	°	L	°	L	°	L	°	L		
9	66	130.0**																					9	
10	64	120.0*																					10	
12	59	105.0	74	48.5	74	72.0	74	31.5															12	
14	55	94.2	72	48.5	72	68.4	72	31.5															14	
16	51	84.8	70	48.5	70	64.3	70	31.5															16	
18	46	77.9	68	48.5	68	59.3	68	31.5	76	31.5	76	41.2	76	28.6									18	
20	40	71.2	66	48.5	66	54.2	66	31.5	75	31.5	75	40.9	75	28.6	80	31.5	80	23.0					20	
25	19	48.7	60	48.5	60	44.6	60	31.5	71	31.5	71	36.4	71	28.6	77	31.5	77	21.7	79	21.8			25	
30			53	41.9	53	37.3	53	31.5	67	31.5	67	31.8	67	27.5	74	28.8	74	20.5	76	21.2	79	17.0	30	
35			47	32.7	47	31.1	47	31.5	63	30.9	63	27.3	63	25.9	71	25.2	71	19.0	74	20.3	76	17.0	35	
40			39	26.3	39	25.0	39	28.8	59	28.7	59	23.4	59	24.2	68	22.0	68	17.8	71	19.5	74	16.9	40	
45			30	21.8	30	20.5	30	24.1	55	24.0	55	20.4	55	21.8	65	19.4	65	16.5	68	18.6	71	15.9	45	
50									50	20.3	50	17.4	50	19.7	62	17.3	62	14.9	66	16.8	69	15.2	50	
55									45	17.2	45	14.6	45	17.7	58	15.4	58	13.4	62	14.9	67	14.1	55	
60									39	14.7	39	12.0	39	15.8	55	13.7	55	12.2	60	13.3	64	12.6	60	
65									33	12.8	33	10.0	33	14.1	51	11.9	51	11.0	57	12.0	61	11.3	65	
70									24	11.1	24	8.2	24	12.5	48	10.2	48	10.1	54	10.6	59	10.3	70	
75															44	8.7	44	9.3	51	9.1	56	9.4	75	
80															40	7.5	40	8.5	47	7.7	53	8.5	80	
85															35	6.4	35	7.8	43	6.6	50	7.3	85	
90															29	5.4	29	7.2	39	5.7	47	6.4	90	
95															21	4.5	21	6.8	35	4.9	44	5.5	95	
100																			30	4.2	41	4.7	100	
110																			13	2.9	32	3.6	110	
120																					21	2.5	120	
Telescoping sequence %																								
Tel. 1	0		50		100		0		50		100		0		100		0		100		100		100	Tel. 1
Tel. 2	0		50		0		33		50		100		67		100		100		100		100		100	Tel. 2
Tel. 3	0		0		0		33		50		0		67		50		100		75		100		100	Tel. 3
Tel. 4	0		0		0		33		50		0		67		50		100		75		100		100	Tel. 4
Code	010/110/210		110		010		210		110		010		210		010		210		010		010		010	Code

** Over rear with superstructure pin engaged.

* With additional equipment.

Operation and maintenance of this machine must be in compliance with the information provided in the "Operation and Maintenance Manual" supplied with this machine.

Counterweight 29,100 lbs

Working Radius (ft)	Lifting capacities in 1,000 lbs according per SAE J765 on telescopic boom On outriggers, 360° working area Outrigger base 15.22 ft														Working Radius (ft)									
	Boom length (ft)																							
	34.1		58.5		58.5		58.5		82.9		82.9		82.9			107.3		107.3		119.6		131.8		
	°	L	°	L	°	L	°	L	°	L	°	L	°	L	°	L	°	L	°	L	°	L		
9	66	111.0																					9	
10	64	104.0																					10	
12	59	92.4	74	48.5	74	72.0	74	31.5															12	
14	55	82.7	72	48.5	72	68.4	72	31.5															14	
16	51	74.7	70	48.5	70	64.3	70	31.5															16	
18	46	65.5	68	48.5	68	57.9	68	31.5	76	31.5	76	41.2	76	28.6									18	
20	40	56.1	66	47.9	66	50.9	66	31.5	75	31.5	75	40.7	75	28.6	80	31.5	80	23.0					20	
25	19	38.8	60	37.1	60	35.5	60	31.5	71	31.5	71	32.9	71	28.6	77	30.4	77	21.7	79	21.8			25	
30			53	27.1	53	25.6	53	28.8	67	28.4	67	25.7	67	27.4	74	25.5	74	20.5	76	21.2	79	17.0	30	
35			47	20.6	47	19.2	47	23.4	63	23.0	63	20.0	63	24.0	71	20.8	71	19.0	74	19.7	76	17.0	35	
40			39	16.1	39	14.8	39	18.8	59	18.3	59	15.5	59	20.1	68	17.0	68	17.7	71	17.1	74	16.7	40	
45			30	12.9	30	11.6	30	15.4	55	15.0	55	12.3	55	16.5	65	14.0	65	15.4	68	14.4	71	14.3	45	
50									50	12.4	50	9.9	50	14.0	62	11.5	62	13.6	66	12.0	69	12.1	50	
55									45	10.4	45	7.9	45	11.9	58	9.5	58	11.9	62	10.0	67	10.2	55	
60									39	8.8	39	6.1	39	10.1	55	7.9	55	10.3	60	8.3	64	8.6	60	
65									33	7.2	33	4.8	33	8.6	51	6.4	51	8.8	57	6.8	61	7.2	65	
70									24	6.2	24	3.7	24	7.5	48	5.3	48	7.7	54	5.6	59	6.0	70	
75															44	4.3	44	6.7	51	4.6	56	5.0	75	
80															40	3.4	40	5.7	47	3.8	53	4.2	80	
85															35	2.7	35	4.9	43	2.9	50	3.4	85	
90															29	2.0	29	4.2	39	2.4	47	2.8	90	
95															21	1.4	21	3.7	35	1.9	44	2.3	95	
100																					41	1.8	100	
Telescoping sequence %																								
Tel. 1	0		50		100		0		50		100		0		100		0		100		100		100	Tel. 1
Tel. 2	0		50		0		33		50		100		67		100		100		100		100		100	Tel. 2
Tel. 3	0		0		0		33		50		0		67		50		100		75		100		100	Tel. 3
Tel. 4	0		0		0		33		50		0		67		50		100		75		100		100	Tel. 4
Code	011/111/211		111		011		211		111		011		211		011		211		011		011		011	Code

Operation and maintenance of this machine must be in compliance with the information provided in the "Operation and Maintenance Manual" supplied with this machine.

Counterweight 26,680 lbs

Working Radius (ft)	Lifting capacities in 1,000 lbs according per SAE J765 on telescopic boom On outriggers, 360° working area Outrigger base 20.57 ft														Working Radius (ft)									
	Boom length (ft)																							
	34.1		58.5		58.5		58.5		82.9		82.9		82.9			107.3		107.3		119.6		131.8		
	°	L	°	L	°	L	°	L	°	L	°	L	°	L	°	L	°	L	°	L	°	L		
9	66	130.0**																					9	
10	64	120.0*																					10	
12	59	105.0	74	48.5	74	72.0	74	31.5															12	
14	55	94.2	72	48.5	72	68.4	72	31.5															14	
16	51	84.8	70	48.5	70	64.3	70	31.5															16	
18	46	77.9	68	48.5	68	59.3	68	31.5	76	31.5	76	41.2	76	28.6									18	
20	40	71.2	66	48.5	66	54.2	66	31.5	75	31.5	75	40.9	75	28.6	80	31.5	80	23.0					20	
25	19	48.7	60	48.5	60	44.6	60	31.5	71	31.5	71	36.4	71	28.6	77	31.5	77	21.7	79	21.8			25	
30			53	40.3	53	37.2	53	31.5	67	31.5	67	31.8	67	27.5	74	28.8	74	20.5	76	21.2	79	17.0	30	
35			47	31.3	47	30.0	47	31.5	63	30.9	63	27.3	63	25.9	71	25.2	71	19.0	74	20.3	76	17.0	35	
40			39	24.9	39	23.7	39	27.7	59	27.5	59	23.3	59	24.2	68	22.0	68	17.8	71	19.5	74	16.9	40	
45			30	20.4	30	19.1	30	23.2	55	22.8	55	19.8	55	21.8	65	19.4	65	16.5	68	18.6	71	15.9	45	
50									50	19.3	50	16.4	50	19.4	62	17.2	62	14.9	66	16.8	69	15.2	50	
55									45	16.3	45	13.5	45	17.2	58	15.0	58	13.4	62	14.9	67	14.1	55	
60									39	13.8	39	11.0	39	15.3	55	13.0	55	12.2	60	13.2	64	12.6	60	
65									33	11.9	33	9.2	33	13.4	51	10.9	51	11.0	57	11.4	61	11.3	65	
70									24	10.3	24	7.5	24	11.8	48	9.4	48	10.1	54	9.9	59	10.2	70	
75															44	8.0	44	9.3	51	8.5	56	9.0	75	
80															40	6.8	40	8.5	47	7.2	53	7.7	80	
85															35	5.6	35	7.8	43	6.1	50	6.6	85	
90															29	4.7	29	7.2	39	5.2	47	5.7	90	
95															21	3.9	21	6.6	35	4.4	44	4.9	95	
100																			30	3.7	41	4.2	100	
110																			13	2.6	32	3.1	110	
120																				21	2.0	21	2.0	120
Telescoping sequence %																								
Tel. 1	0		50		100		0		50		100		0		100		0		100		100		100	Tel. 1
Tel. 2	0		50		0		33		50		100		67		100		100		100		100		100	Tel. 2
Tel. 3	0		0		0		33		50		0		67		50		100		75		100		100	Tel. 3
Tel. 4	0		0		0		33		50		0		67		50		100		75		100		100	Tel. 4
Code	020/120/220		120		020		220		120		020		220		020		220		020		020		020	Code

** Over rear with superstructure pin engaged.

* With additional equipment.

Operation and maintenance of this machine must be in compliance with the information provided in the "Operation and Maintenance Manual" supplied with this machine.

Counterweight 26,680 lbs

Working Radius (ft)	Lifting capacities in 1,000 lbs according per SAE J765 on telescopic boom On outriggers, 360° working area Outrigger base 15.22 ft														Working Radius (ft)									
	Boom length (ft)																							
	34.1		58.5		58.5		58.5		82.9		82.9		82.9			107.3		107.3		119.6		131.8		
	°	L	°	L	°	L	°	L	°	L	°	L	°	L	°	L	°	L	°	L	°	L		
9	66	111.0																					9	
10	64	104.0																					10	
12	59	91.9	74	48.5	74	72.0	74	31.5															12	
14	55	82.2	72	48.5	72	68.4	72	31.5															14	
16	51	74.2	70	48.5	70	64.3	70	31.5															16	
18	46	64.4	68	48.5	68	56.0	68	31.5	76	31.5	76	41.2	76	28.6									18	
20	40	54.3	66	47.7	66	47.2	66	31.5	75	31.5	75	40.6	75	28.6	80	31.5	80	23.0					20	
25	19	36.8	60	35.3	60	33.7	60	31.5	71	31.5	71	31.4	71	28.6	77	29.7	77	21.7	79	21.8			25	
30			53	25.6	53	24.1	53	28.1	67	27.4	67	24.2	67	27.3	74	24.0	74	20.5	76	21.2	79	17.0	30	
35			47	19.5	47	18.1	47	22.1	63	21.7	63	18.8	63	23.2	71	19.6	71	19.0	74	19.0	76	17.0	35	
40			39	15.3	39	13.7	39	17.9	59	17.5	59	14.6	59	19.0	68	16.2	68	17.6	71	16.0	74	15.4	40	
45			30	12.1	30	10.7	30	14.5	55	14.3	55	11.4	55	15.6	65	13.1	65	15.2	68	13.3	71	13.4	45	
50									50	11.8	50	9.0	50	13.1	62	10.8	62	13.1	66	11.1	69	11.4	50	
55									45	9.7	45	7.1	45	11.1	58	8.9	58	11.3	62	9.3	67	9.5	55	
60									39	8.1	39	5.5	39	9.4	55	7.2	55	9.7	60	7.7	64	7.9	60	
65									33	6.8	33	4.1	33	7.9	51	5.9	51	8.3	57	6.3	61	6.8	65	
70									24	5.7	24	3.1	24	7.0	48	4.8	48	7.1	54	5.3	59	5.7	70	
75															44	3.8	44	6.1	51	4.3	56	4.7	75	
80															40	2.9	40	5.3	47	3.4	53	3.8	80	
85															35	2.2	35	4.7	43	2.7	50	3.1	85	
90															29	1.6	29	4.0	39	2.0	47	2.5	90	
95																			21	3.4	35	1.4	95	
100																							100	
Telescoping sequence %																								
Tel. 1	0		50		100		0		50		100		0		100		0		100		100		100	Tel. 1
Tel. 2	0		50		0		33		50		100		67		100		100		100		100		100	Tel. 2
Tel. 3	0		0		0		33		50		0		67		50		100		75		100		100	Tel. 3
Tel. 4	0		0		0		33		50		0		67		50		100		75		100		100	Tel. 4
Code	021/121/221		121		021		221		121		021		221		021		221		021		021		021	Code

Operation and maintenance of this machine must be in compliance with the information provided in the "Operation and Maintenance Manual" supplied with this machine.

Counterweight 19,620 lbs

Working Radius (ft)	Lifting capacities in 1,000 lbs according per SAE J765 on telescopic boom														Working Radius (ft)								
	On outriggers, 360° working area																						
	Outrigger base 20.57 ft																						
Boom length (ft)																							
	34.1		58.5		58.5		58.5		82.9		82.9		82.9		107.3		107.3		119.6		131.8		
	°	L	°	L	°	L	°	L	°	L	°	L	°	L	°	L	°	L	°	L	°	L	
9	66	130.0**																					9
10	64	120.0*																					10
12	59	105.0	74	48.5	74	72.0	74	31.5															12
14	55	94.0	72	48.5	72	68.4	72	31.5															14
16	51	84.7	70	48.5	70	64.3	70	31.5															16
18	46	77.4	68	48.5	68	59.3	68	31.5	76	31.5	76	41.2	76	28.6									18
20	40	70.2	66	48.5	66	54.2	66	31.5	75	31.5	75	40.9	75	28.6	80	31.5	80	23.0					20
25	19	48.4	60	46.0	60	44.6	60	31.5	71	31.5	71	36.4	71	28.6	77	31.5	77	21.7	79	21.8			25
30			53	35.6	53	34.1	53	31.5	67	31.5	67	31.8	67	27.5	74	28.8	74	20.5	76	21.2	79	17.0	30
35			47	27.5	47	26.0	47	29.7	63	29.4	63	26.4	63	25.9	71	25.2	71	19.0	74	20.3	76	17.0	35
40			39	21.7	39	20.3	39	24.3	59	23.9	59	20.9	59	24.1	68	21.9	68	17.8	71	19.5	74	16.9	40
45			30	17.4	30	16.1	30	20.0	55	19.6	55	16.7	55	20.9	65	18.5	65	16.5	68	18.1	71	15.9	45
50									50	16.3	50	13.4	50	17.7	62	15.4	62	14.9	66	15.7	69	15.1	50
55									45	13.7	45	10.8	45	15.0	58	12.7	58	13.4	62	13.3	67	13.6	55
60									39	11.6	39	8.7	39	12.9	55	10.6	55	12.2	60	11.1	64	11.6	60
65									33	9.9	33	7.0	33	11.3	51	8.7	51	11.0	57	9.4	61	9.9	65
70									24	8.4	24	5.5	24	9.8	48	7.4	48	9.9	54	7.9	59	8.4	70
75															44	6.2	44	8.8	51	6.6	56	7.1	75
80															40	5.1	40	7.8	47	5.5	53	6.0	80
85															35	4.2	35	6.8	43	4.4	50	4.9	85
90															29	3.3	29	5.9	39	3.7	47	4.2	90
95															21	2.6	21	5.2	35	2.9	44	3.4	95
100																			30	2.3	41	2.7	100
110																			13	1.3	32	1.8	110
Telescoping sequence %																							
Tel. 1	0	50	100	0	50	100	0	100	0	100	0	100	0	100	0	100	0	100	100	100	Tel. 1		
Tel. 2	0	50	0	33	50	100	67	100	100	100	100	100	100	100	100	100	100	100	100	100	Tel. 2		
Tel. 3	0	0	0	33	50	0	67	50	100	75	100	100	100	100	100	100	100	100	100	100	Tel. 3		
Tel. 4	0	0	0	33	50	0	67	50	100	75	100	100	100	100	100	100	100	100	100	100	Tel. 4		
Code	030/130/230	130	030	230	130	030	230	030	230	030	230	030	230	030	230	030	230	030	230	030	Code		

** Over rear with superstructure pin engaged.

* With additional equipment.

Operation and maintenance of this machine must be in compliance with the information provided in the "Operation and Maintenance Manual" supplied with this machine.

Counterweight 19,620 lbs

Working Radius (ft)	Lifting capacities in 1,000 lbs according per SAE J765 on telescopic boom														Working Radius (ft)								
	On outriggers, 360° working area																						
	Outrigger base 15.22 ft																						
Boom length (ft)																							
	34.1		58.5		58.5		58.5		82.9		82.9		82.9		107.3		107.3		119.6		131.8		
	°	L	°	L	°	L	°	L	°	L	°	L	°	L	°	L	°	L	°	L	°	L	
9	66	110.0																					9
10	64	102.0																					10
12	59	91.2	74	48.5	74	72.0	74	31.5															12
14	55	81.6	72	48.5	72	65.1	72	31.5															14
16	51	68.6	70	48.5	70	55.1	70	31.5															16
18	46	56.9	68	45.7	68	47.2	68	31.5	76	31.5	76	39.0	76	28.6									18
20	40	46.7	66	41.9	66	40.0	66	31.5	75	31.5	75	35.9	75	28.6	80	31.5	80	23.0					20
25	19	31.6	60	29.9	60	28.1	60	30.3	71	29.2	71	26.3	71	28.6	77	25.9	77	21.7	79	21.8			25
30			53	21.5	53	19.9	53	24.5	67	23.1	67	19.8	67	24.7	74	20.1	74	20.5	76	19.5	79	17.0	30
35			47	16.2	47	14.6	47	18.7	63	18.2	63	15.3	63	20.0	71	16.0	71	19.0	74	16.2	76	15.9	35
40			39	12.2	39	10.9	39	14.9	59	14.4	59	11.6	59	16.0	68	12.9	68	16.0	71	13.2	74	13.2	40
45			30	9.5	30	8.2	30	12.0	55	11.6	55	8.9	55	13.1	65	10.6	65	13.3	68	10.8	71	11.0	45
50									50	9.5	50	6.9	50	10.9	62	8.5	62	11.1	66	9.0	69	9.2	50
55									45	7.8	45	5.2	45	9.1	58	6.7	58	9.4	62	7.3	67	7.6	55
60									39	6.2	39	3.7	39	7.5	55	5.3	55	7.9	60	5.7	64	6.2	60
65									33	5.0	33	2.6	33	6.3	51	4.1	51	6.6	57	4.6	61	5.0	65
70									24	4.1	24	1.7	24	5.3	48	3.2	48	5.5	54	3.5	59	4.0	70
75															44	2.4	44	4.6	51	2.7	56	3.1	75
80															40	1.4	40	3.8	47	2.0	53	2.5	80
85																			35	3.3	43	1.4	85
90																			29	2.8	47	1.3	90
95																			21	2.3			95
Telescoping sequence %																							
Tel. 1	0	50	100	0	50	100	0	100	0	100	0	100	0	100	0	100	0	100	100	100	Tel. 1		
Tel. 2	0	50	0	33	50	100	67	100	100	100	100	100	100	100	100	100	100	100	100	100	Tel. 2		
Tel. 3	0	0	0	33	50	0	67	50	100	75	100	100	100	100	100	100	100	100	100	100	Tel. 3		
Tel. 4	0	0	0	33	50	0	67	50	100	75	100	100	100	100	100	100	100	100	100	100	Tel. 4		
Code	031/131/231	131	031	231	131	031	231	031	231	031	231	031	231	031	231	031	231	031	231	031	Code		

Operation and maintenance of this machine must be in compliance with the information provided in the "Operation and Maintenance Manual" supplied with this machine.

Counterweight 29,100 lbs

Working Radius (ft)	Lifting capacities in 1,000 lbs according per SAE J765 on telescopic boom On tire, over rear						Working Radius (ft)
	Boom length (ft)						
	°	L	34.1 Over rear	°	L	58.5 Over rear	
10	64	45.9					10
12	59	41.2		74	28.7		12
14	55	36.8		72	28.7		14
16	51	31.6		70	28.5		16
18	46	27.1		68	26.1		18
20	40	23.1		66	23.2		20
25	19	16.6		60	17.8		25
30				53	13.6		30
35				47	10.7		35
40				39	8.4		40
45				30	6.7		45
Telescoping sequence %							
Tel. 1	0		0				Tel. 1
Tel. 2	0		33				Tel. 2
Tel. 3	0		33				Tel. 3
Tel. 4	0		33				Tel. 4
Code	216						Code

Operation and maintenance of this machine must be in compliance with the information provided in the "Operation and Maintenance Manual" supplied with this machine.

Counterweight 26,680 lbs

Working Radius (ft)	Lifting capacities in 1,000 lbs according per SAE J765 on telescopic boom On tire, over rear						Working Radius (ft)
	Boom length (ft)						
	°	L	34.1 Over rear	°	L	58.5 Over rear	
10	64	45.9					10
12	59	41.1		74	28.7		12
14	55	35.9		72	28.7		14
16	51	30.2		70	27.7		16
18	46	25.9		68	25.0		18
20	40	22.0		66	22.1		20
25	19	15.8		60	17.0		25
30				53	12.9		30
35				47	10.0		35
40				39	7.9		40
45				30	6.3		45
Telescoping sequence %							
Tel. 1	0		0				Tel. 1
Tel. 2	0		33				Tel. 2
Tel. 3	0		33				Tel. 3
Tel. 4	0		33				Tel. 4
Code	226						Code

Operation and maintenance of this machine must be in compliance with the information provided in the "Operation and Maintenance Manual" supplied with this machine.

Counterweight 19,620 lbs

Working Radius (ft)	Lifting capacities in 1,000 lbs according per SAE J765 on telescopic boom On tire, over rear						Working Radius (ft)
	Boom length (ft)						
	°	L	34.1 Over rear	°	L	58.5 Over rear	
10	64	44.1					10
12	59	36.7		74	28.7		12
14	55	30.9		72	27.4		14
16	51	26.1		70	24.1		16
18	46	22.2		68	21.2		18
20	40	18.8		66	18.7		20
25	19	13.2		60	14.2		25
30				53	10.8		30
35				47	8.2		35
40				39	6.2		40
45				30	4.9		45
Telescoping sequence %							
Tel. 1	0		0				Tel. 1
Tel. 2	0		33				Tel. 2
Tel. 3	0		33				Tel. 3
Tel. 4	0		33				Tel. 4
Code	236						Code

Operation and maintenance of this machine must be in compliance with the information provided in the "Operation and Maintenance Manual" supplied with this machine.

Counterweight 29,100 lbs

Working Radius (ft)	Lifting capacities in 1,000 lbs according per SAE J765 on fly jib 29.5 ft / 52.5 ft															Working Radius (ft)			
	On outriggers, 360° working area																		
	Outrigger base 20.57 ft																		
	Boom length 34.1 ft to 119.6 ft					Boom length 119.6 ft to 131.8 ft					Boom length 34.1 ft to 131.8 ft								
Fly jib 29.5 ft offset					Fly jib 29.5 ft offset					Fly jib 52.5 ft offset									
5°			17°			30°			5°			17°			30°				
°	L		°	L		°	L		°	L		°	L		°	L			
35	77	11.6				78	9.2											35	
40	76	11.6	77	9.6		79	7.2	77	9.2	79	8.2				79	5.3		40	
45	73	11.2	75	9.2	76	7.0	75	9.2	77	8.2	79	6.8	77	5.3				45	
50	72	10.9	73	8.6	75	6.6	74	9.1	75	8.0	77	6.6	76	5.3	79	4.4		50	
55	70	10.5	71	8.1	73	6.3	72	8.8	73	7.7	75	6.4	74	5.3	77	4.3	79	3.2	55
60	68	10.0	69	7.6	71	6.0	71	8.6	72	7.5	73	6.1	73	5.2	76	4.2	78	3.1	60
65	66	9.2	67	7.1	68	5.7	68	8.4	70	7.3	71	6.0	71	5.0	74	4.0	76	3.0	65
70	64	8.5	65	6.7	66	5.5	67	8.1	68	7.0	69	5.8	70	4.9	73	3.9	75	3.0	70
75	62	7.9	63	6.4	64	5.4	65	7.9	66	6.8	67	5.6	68	4.7	71	3.8	73	3.0	75
80	59	7.4	60	6.1	61	5.2	63	7.6	64	6.5	65	5.4	67	4.6	69	3.6	71	2.9	80
85	57	6.9	58	5.8	59	5.0	61	6.8	62	6.2	63	5.2	65	4.5	67	3.5	69	2.8	85
90	54	6.0	56	5.6	57	4.8	59	6.1	60	5.9	61	5.0	64	4.2	66	3.3	68	2.8	90
95	52	5.1	53	5.2	54	4.7	57	5.3	58	5.5	59	4.9	62	3.9	64	3.2	66	2.7	95
100	49	4.3	50	4.6	51	4.5	54	4.5	55	4.9	56	4.6	60	3.7	62	3.1	64	2.6	100
110	43	3.0	44	3.2	45	3.4	49	3.2	50	3.5	51	3.7	56	3.3	58	2.8	60	2.5	110
120	36	1.9	37	2.0	37	2.1	43	2.1	45	2.3	45	2.5	52	3.0	54	2.6	55	2.4	120
130							37	1.2	38	1.3	38	1.4	48	2.3	50	2.4	51	2.2	130
140													44	1.7	45	1.9	46	2.1	140
150															39	1.2	39	1.3	150
Telescoping sequence %																			
Tel. 1	100					100					100					Tel. 1			
Tel. 2	100					100					100					Tel. 2			
Tel. 3	75					100					100					Tel. 3			
Tel. 4	75					100					100					Tel. 4			
Code	410		411		412	410		411		412	510		511		512			Code	

Operation and maintenance of this machine must be in compliance with the information provided in the "Operation and Maintenance Manual" supplied with this machine.

Counterweight 29,100 lbs

Working Radius (ft)	Lifting capacities in 1,000 lbs according per SAE J765 on fly jib 29.5 ft / 52.5 ft															Working Radius (ft)			
	On outriggers, 360° working area																		
	Outrigger base 15.22 ft																		
	Boom length 34.1 ft to 119.6 ft					Boom length 119.6 ft to 131.8 ft					Boom length 34.1 ft to 131.8 ft								
Fly jib 29.5 ft offset					Fly jib 29.5 ft offset					Fly jib 52.5 ft offset									
5°			17°			30°			5°			17°			30°				
°	L		°	L		°	L		°	L		°	L		°	L			
35	77	11.6				78	9.2											35	
40	76	11.6	77	9.6		79	7.2	77	9.2	79	8.2				79	5.3		40	
45	73	11.2	75	9.2	76	7.0	75	9.2	77	8.2	79	6.8	77	5.3				45	
50	72	10.3	73	8.6	75	6.6	74	9.1	75	8.0	77	6.6	76	5.3	79	4.4		50	
55	70	9.2	71	8.1	73	6.3	72	8.8	73	7.7	75	6.4	74	5.3	77	4.3	79	3.2	55
60	68	8.2	69	7.6	71	6.0	71	8.4	72	7.5	73	6.1	73	5.2	76	4.2	78	3.1	60
65	66	7.0	67	7.1	68	5.7	68	7.3	70	7.3	71	6.0	71	5.0	74	4.0	76	3.0	65
70	64	5.9	65	6.3	66	5.5	67	6.2	68	6.5	69	5.8	70	4.9	73	3.9	75	3.0	70
75	62	4.8	63	5.3	64	5.1	65	5.2	66	5.6	67	5.4	68	4.7	71	3.8	73	3.0	75
80	59	3.9	60	4.3	61	4.6	63	4.2	64	4.6	65	4.8	67	4.5	69	3.6	71	2.9	80
85	57	3.1	58	3.6	59	3.9	61	3.4	62	3.8	63	4.1	65	4.1	67	3.5	69	2.8	85
90	54	2.5	56	2.8	57	3.1	59	2.7	60	3.0	61	3.4	64	3.7	66	3.3	68	2.8	90
95	52	1.9	53	2.2	54	2.4	57	2.1	58	2.4	59	2.7	62	3.2	64	3.2	66	2.7	95
100			50	1.6	51	1.8	54	1.6	55	1.8	56	2.0	60	2.6	62	3.0	64	2.6	100
110							54	1.6	55	1.8	56	2.0	60	2.6	62	3.0	64	2.6	110
120													56	1.7	58	2.1	60	2.3	120
Telescoping sequence %																			
Tel. 1	100					100					100					Tel. 1			
Tel. 2	100					100					100					Tel. 2			
Tel. 3	75					100					100					Tel. 3			
Tel. 4	75					100					100					Tel. 4			
Code	413		414		415	413		414		415	513		514		515			Code	

Operation and maintenance of this machine must be in compliance with the information provided in the "Operation and Maintenance Manual" supplied with this machine.

Counterweight 26,680 lbs

Working Radius (ft)	Lifting capacities in 1,000 lbs according per SAE J765 on fly jib 29.5 ft / 52.5 ft															Working Radius (ft)			
	On outriggers, 360° working area																		
	Outrigger base 20.57 ft																		
	Boom length 34.1 ft to 119.6 ft					Boom length 119.6 ft to 131.8 ft					Boom length 34.1 ft to 131.8 ft								
Fly jib 29.5 ft offset					Fly jib 29.5 ft offset					Fly jib 52.5 ft offset									
5°		17°		30°		5°		17°		30°		5°		17°		30°			
°	L	°	L	°	L	°	L	°	L	°	L	°	L	°	L	°	L		
35	77	11.6				78	9.2											35	
40	76	11.6	77	9.6	79	7.2	77	9.2	79	8.2			79	5.3				40	
45	73	11.2	75	9.2	76	7.0	75	9.2	77	8.2	79	6.8	77	5.3				45	
50	72	10.9	73	8.6	75	6.6	74	9.1	75	8.0	77	6.6	76	5.3	79	4.4		50	
55	70	10.5	71	8.1	73	6.3	72	8.8	73	7.7	75	6.4	74	5.3	77	4.3	79	3.2	55
60	68	10.0	69	7.6	71	6.0	71	8.6	72	7.5	73	6.1	73	5.2	76	4.2	78	3.1	60
65	66	9.2	67	7.1	68	5.7	68	8.4	70	7.3	71	6.0	71	5.0	74	4.0	76	3.0	65
70	64	8.5	65	6.7	66	5.5	67	8.1	68	7.0	69	5.8	70	4.9	73	3.9	75	3.0	70
75	62	7.9	63	6.4	64	5.4	65	7.9	66	6.8	67	5.6	68	4.7	71	3.8	73	3.0	75
80	59	7.3	60	6.1	61	5.2	63	7.5	64	6.5	65	5.4	67	4.6	69	3.6	71	2.9	80
85	57	6.4	58	5.8	59	5.0	61	6.6	62	6.2	63	5.2	65	4.5	67	3.5	69	2.8	85
90	54	5.4	56	5.6	57	4.8	59	5.7	60	5.8	61	5.0	64	4.2	66	3.3	68	2.8	90
95	52	4.6	53	4.9	54	4.7	57	4.8	58	5.2	59	4.9	62	3.9	64	3.2	66	2.7	95
100	49	3.8	50	4.1	51	4.4	54	4.0	55	4.4	56	4.5	60	3.7	62	3.1	64	2.6	100
110	43	2.5	44	2.7	45	3.0	49	2.7	50	3.0	51	3.2	56	3.3	58	2.8	60	2.5	110
120	36	1.5	37	1.7	37	1.7	43	1.8	45	2.0	45	2.1	52	2.9	54	2.6	55	2.4	120
130													48	2.0	50	2.3	51	2.2	130
140													44	1.3	45	1.5	46	1.8	140
Telescoping sequence %																			
Tel. 1	100					100					100					Tel. 1			
Tel. 2	100					100					100					Tel. 2			
Tel. 3	75					100					100					Tel. 3			
Tel. 4	75					100					100					Tel. 4			
Code	420	421	422	420	421	422	520	521	522	Code									

Operation and maintenance of this machine must be in compliance with the information provided in the "Operation and Maintenance Manual" supplied with this machine.

Counterweight 26,680 lbs

Working Radius (ft)	Lifting capacities in 1,000 lbs according per SAE J765 on fly jib 29.5 ft / 52.5 ft															Working Radius (ft)			
	On outriggers, 360° working area																		
	Outrigger base 15.22 ft																		
	Boom length 34.1 ft to 119.6 ft					Boom length 119.6 ft to 131.8 ft					Boom length 34.1 ft to 131.8 ft								
Fly jib 29.5 ft offset					Fly jib 29.5 ft offset					Fly jib 52.5 ft offset									
5°		17°		30°		5°		17°		30°		5°		17°		30°			
°	L	°	L	°	L	°	L	°	L	°	L	°	L	°	L	°	L		
35	77	11.6				78	9.2											35	
40	76	11.6	77	9.6	79	7.2	77	9.2	79	8.2			79	5.3				40	
45	73	11.2	75	9.2	76	7.0	75	9.2	77	8.2	79	6.8	77	5.3				45	
50	72	10.3	73	8.6	75	6.6	74	9.1	75	8.0	77	6.6	76	5.3	79	4.4		50	
55	70	9.0	71	8.1	73	6.3	72	8.5	73	7.7	75	6.4	74	5.3	77	4.3	79	3.2	55
60	68	7.6	69	7.5	71	6.0	71	7.6	72	7.4	73	6.1	73	5.2	76	4.2	78	3.1	60
65	66	6.4	67	6.5	68	5.7	68	6.6	70	6.9	71	6.0	71	5.0	74	4.0	76	3.0	65
70	64	5.3	65	5.7	66	5.5	67	5.6	68	6.0	69	5.8	70	4.9	73	3.9	75	3.0	70
75	62	4.3	63	4.8	64	5.1	65	4.7	66	5.1	67	5.3	68	4.7	71	3.8	73	3.0	75
80	59	3.5	60	3.9	61	4.3	63	3.8	64	4.2	65	4.5	67	4.5	69	3.6	71	2.9	80
85	57	2.8	58	3.1	59	3.5	61	3.0	62	3.4	63	3.7	65	4.1	67	3.5	69	2.8	85
90	54	2.1	56	2.5	57	2.8	59	2.3	60	2.7	61	2.9	64	3.4	66	3.3	68	2.8	90
95	52	1.6	53	1.8	54	2.1	57	1.8	58	2.1	59	2.3	62	2.8	64	3.1	66	2.7	95
100					51	1.3			55	1.5	56	1.7	60	2.3	62	2.7	64	2.6	100
110													56	1.4	58	1.8	60	2.1	110
120																	55	1.3	120
Telescoping sequence %																			
Tel. 1	100					100					100					Tel. 1			
Tel. 2	100					100					100					Tel. 2			
Tel. 3	75					100					100					Tel. 3			
Tel. 4	75					100					100					Tel. 4			
Code	423	424	425	423	424	425	523	524	525	Code									

Operation and maintenance of this machine must be in compliance with the information provided in the "Operation and Maintenance Manual" supplied with this machine.

Counterweight 19,620 lbs

Working Radius (ft)	Lifting capacities in 1,000 lbs according per SAE J765 on fly jib 29.5 ft / 52.5 ft															Working Radius (ft)			
	On outriggers, 360° working area																		
	Outrigger base 20.57 ft																		
	Boom length 34.1 ft to 119.6 ft					Boom length 119.6 ft to 131.8 ft					Boom length 34.1 ft to 131.8 ft								
Fly jib 29.5 ft offset					Fly jib 29.5 ft offset					Fly jib 52.5 ft offset									
5°		17°		30°		5°		17°		30°		5°		17°		30°			
°	L	°	L	°	L	°	L	°	L	°	L	°	L	°	L	°	L		
35	77	11.6				78	9.2											35	
40	76	11.6	77	9.6	79	7.2	77	9.2	79	8.2			79	5.3				40	
45	73	11.2	75	9.2	76	7.0	75	9.2	77	8.2	79	6.8	77	5.3				45	
50	72	10.9	73	8.6	75	6.6	74	9.1	75	8.0	77	6.6	76	5.3	79	4.4		50	
55	70	10.5	71	8.1	73	6.3	72	8.8	73	7.7	75	6.4	74	5.3	77	4.3	79	3.2	55
60	68	10.0	69	7.6	71	6.0	71	8.6	72	7.5	73	6.1	73	5.2	76	4.2	78	3.1	60
65	66	9.2	67	7.1	68	5.7	68	8.4	70	7.3	71	6.0	71	5.0	74	4.0	76	3.0	65
70	64	8.0	65	6.7	66	5.5	67	8.0	68	7.0	69	5.8	70	4.9	73	3.9	75	3.0	70
75	62	6.8	63	6.4	64	5.4	65	7.1	66	6.8	67	5.6	68	4.7	71	3.8	73	3.0	75
80	59	5.7	60	6.0	61	5.2	63	6.0	64	6.3	65	5.4	67	4.6	69	3.6	71	2.9	80
85	57	4.8	58	5.1	59	5.0	61	5.0	62	5.4	63	5.2	65	4.5	67	3.5	69	2.8	85
90	54	3.9	56	4.3	57	4.5	59	4.2	60	4.6	61	4.7	64	4.2	66	3.3	68	2.8	90
95	52	3.2	53	3.5	54	3.7	57	3.4	58	3.8	59	4.0	62	3.9	64	3.2	66	2.7	95
100	49	2.5	50	2.7	51	2.9	54	2.7	55	3.0	56	3.3	60	3.6	62	3.1	64	2.6	100
110	43	1.4	44	1.5	45	1.7	49	1.5	50	1.7	51	2.0	56	2.7	58	2.8	60	2.5	110
120													52	1.8	54	2.0	55	2.3	120
130															50	1.4	51	1.7	130
Telescoping sequence %																			
Tel. 1	100					100					Tel. 1								
Tel. 2	100					100					Tel. 2								
Tel. 3	75					100					Tel. 3								
Tel. 4	75					100					Tel. 4								
Code	430	431	432	430	431	432	530	531	532	Code									

Operation and maintenance of this machine must be in compliance with the information provided in the "Operation and Maintenance Manual" supplied with this machine.

Counterweight 19,620 lbs

Working Radius (ft)	Lifting capacities in 1,000 lbs according per SAE J765 on fly jib 29.5 ft / 52.5 ft															Working Radius (ft)				
	On outriggers, 360° working area																			
	Outrigger base 15.22 ft																			
	Boom length 34.1 ft to 119.6 ft					Boom length 119.6 ft to 131.8 ft					Boom length 34.1 ft to 131.8 ft									
Fly jib 29.5 ft offset					Fly jib 29.5 ft offset					Fly jib 52.5 ft offset										
5°		17°		30°		5°		17°		30°		5°		17°		30°				
°	L	°	L	°	L	°	L	°	L	°	L	°	L	°	L	°	L			
35	77	11.6				78	9.2											35		
40	76	11.5	77	9.6	79	7.2	77	9.2	79	8.2			79	5.3				40		
45	73	10.1	75	9.2	76	7.0	75	9.2	77	8.2	79	6.8	77	5.3				45		
50	72	8.4	73	8.4	75	6.6	74	8.4	75	8.0	77	6.6	76	5.3	79	4.4		50		
55	70	7.0	71	7.3	73	6.3	72	7.2	73	7.4	75	6.4	74	5.3	77	4.3	79	3.2	55	
60	68	5.7	69	6.2	71	5.9	71	6.0	72	6.3	73	6.1	73	5.2	76	4.2	78	3.1	60	
65	66	4.7	67	5.0	68	5.2	68	4.9	70	5.3	71	5.5	71	5.0	74	4.0	76	3.0	65	
70	64	3.8	65	4.1	66	4.5	67	4.0	68	4.4	69	4.7	70	4.6	73	3.9	75	3.0	70	
75	62	3.0	63	3.3	64	3.7	65	3.2	66	3.6	67	4.0	68	4.0	71	3.8	73	3.0	75	
80	59	2.3	60	2.6	61	2.9	63	2.5	64	2.8	65	3.2	67	3.4	69	3.5	71	2.9	80	
85	57	1.6	58	1.9	59	2.2	61	1.8	62	2.1	63	2.5	65	2.7	67	3.0	69	2.8	85	
90			56	1.3	57	1.6	59	1.2	60	1.5	61	1.8	64	2.2	66	2.5	68	2.8	90	
95													62	1.7	64	2.1	66	2.5	95	
100															62	1.6	64	2.0	100	
110																60	1.2	60	1.2	110
Telescoping sequence %																				
Tel. 1	100					100					Tel. 1									
Tel. 2	100					100					Tel. 2									
Tel. 3	75					100					Tel. 3									
Tel. 4	75					100					Tel. 4									
Code	433	434	435	433	434	435	533	534	535	Code										

Operation and maintenance of this machine must be in compliance with the information provided in the "Operation and Maintenance Manual" supplied with this machine.

Counterweight 0 lbs (Optional equipment required)

Working Radius (ft)	Lifting capacities in 1,000 lbs according per SAE J765 on telescopic boom On outriggers, 360° working area Outrigger base 20.57 ft																Working Radius (ft)							
	Boom length (ft)																							
	34.1		58.5		58.5		58.5		82.9		82.9		82.9		107.3			107.3		119.6		131.8		
	°	L	°	L	°	L	°	L	°	L	°	L	°	L	°	L		°	L	°	L	°	L	
10	64	113.0																					10	
12	59	100.0	74	48.5	74	72.0	74	31.5															12	
14	55	87.1	72	48.5	72	68.4	72	31.5															14	
16	51	75.8	70	48.5	70	61.0	70	31.5															16	
18	46	62.7	68	47.3	68	51.3	68	31.5	76	31.5	76	39.0	76	28.6									18	
20	40	49.8	66	45.1	66	42.0	66	31.5	75	31.5	75	35.9	75	28.6	80	31.5	80	23.0					20	
25	19	32.0	60	30.6	60	27.9	60	30.3	71	29.1	71	26.3	71	28.6	77	25.4	77	21.7	79	21.8			25	
30			53	21.0	53	18.8	53	24.3	67	22.2	67	18.9	67	23.6	74	19.0	74	20.5	76	18.8	79	17.0	30	
35			47	15.2	47	13.0	47	18.1	63	17.0	63	14.5	63	18.8	71	14.5	71	17.9	74	14.7	76	14.7	35	
40			39	11.3	39	9.1	39	14.2	59	13.3	59	10.7	59	14.9	68	11.3	68	14.7	71	11.6	74	11.6	40	
45			30	8.5	30	6.5	30	11.3	55	10.5	55	7.8	55	12.0	65	8.7	65	12.2	68	9.3	71	9.4	45	
50									50	8.1	50	5.6	50	9.7	62	6.8	62	10.0	66	7.3	69	7.7	50	
55									45	6.3	45	3.9	45	7.8	58	5.2	58	8.2	62	5.7	67	6.1	55	
60									39	4.8	39	2.4	39	6.4	55	3.7	55	6.6	60	4.4	64	4.7	60	
65									33	3.7	33	1.2	33	5.2	51	2.6	51	5.4	57	3.2	61	3.7	65	
70									24	2.6			24	4.2	48	1.5	48	4.4	54	2.2	59	2.6	70	
75																		44	3.6			56	1.8	75
80																		40	2.9					80
85																		35	2.2					85
90																		29	1.7					90
Telescoping sequence %																								
Tel. 1	0		50		100		0		50		100		0		100		0		100		100		Tel. 1	
Tel. 2	0		50		0		33		50		100		67		100		100		100		100		Tel. 2	
Tel. 3	0		0		0		33		50		0		67		50		100		75		100		Tel. 3	
Tel. 4	0		0		0		33		50		0		67		50		100		75		100		Tel. 4	
Code	090/190/290		190		090		290		190		090		290		090		290		090		090		Code	

Operation and maintenance of this machine must be in compliance with the information provided in the "Operation and Maintenance Manual" supplied with this machine.

Counterweight 0 lbs (Optional equipment required)

Working Radius (ft)	Lifting capacities in 1,000 lbs according per SAE J765 on fly jib 29.5 ft / 52.5 ft On outriggers, 360° working area Outrigger base 20.57 ft																Working Radius (ft)						
	Boom length 34.1 ft to 119.6 ft				Boom length 119.6 ft to 131.8 ft				Boom length 34.1 ft to 131.8 ft														
	Fly jib 29.5 ft offset				Fly jib 29.5 ft offset				Fly jib 52.5 ft offset														
	°	5°	17°	30°	°	5°	17°	30°	°	5°	17°	30°											
35	77	11.6			78	9.2																	35
40	76	11.0	77	9.6	79	7.2	77	9.2	79	8.2			79	5.3									40
45	73	8.8	75	9.2	76	7.0	75	8.4	77	8.2	79	6.8	77	5.3									45
50	72	7.0	73	7.9	75	6.6	74	7.0	75	7.5	77	6.6	76	5.3	79	4.4							50
55	70	5.5	71	6.4	73	6.3	72	5.5	73	6.4	75	6.4	74	5.3	77	4.3	79	3.2					55
60	68	4.2	69	5.0	71	5.8	71	4.3	72	5.1	73	6.0	73	5.1	76	4.2	78	3.1					60
65	66	3.2	67	3.9	68	4.7	68	3.3	70	4.0	71	4.8	71	4.4	74	4.0	76	3.0					65
70	64	2.4	65	2.9	66	3.6	67	2.5	68	3.0	69	3.7	70	3.6	73	3.9	75	3.0					70
75	62	1.6	63	2.1	64	2.7	65	1.7	66	2.2	67	2.8	68	2.8	71	3.6	73	3.0					75
80			60	1.2	61	1.9			64	1.3	65	2.0	67	2.1	69	3.0	71	2.9					80
85					59	1.1					63	1.4	65	1.5	67	2.4	69	2.8					85
90															66	1.7	68	2.4					90
95																	66	1.9					95
100																	64	1.2					100
Telescoping sequence %																							
Tel. 1			100												100								Tel. 1
Tel. 2			100												100								Tel. 2
Tel. 3			75												100								Tel. 3
Tel. 4			75												100								Tel. 4
Code	490		491		492		490		491		492		590		591		592						Code

Operation and maintenance of this machine must be in compliance with the information provided in the "Operation and Maintenance Manual" supplied with this machine.

WARNING AND OPERATING INSTRUCTIONS FOR LIFTING CAPACITIES ATF-650XL

GENERAL

1. Total rated loads shown on the TADANO LOAD RATING CHART apply only to the machine as originally manufactured and normally equipped by TADANO. Modifications to the machine or use of optional equipment other than that specified can result in a reduction of capacity.
2. Construction equipment can be dangerous if improperly operated or maintained. Operation and maintenance of this machine must be in compliance with the information in the operation, safety and maintenance manual supplied with the machine. If this manual is missing, order replacement through the distributor.
3. The operator and other personnel associated with this machine shall fully acquaint themselves with the latest applicable American National Standards Institute (ANSI) safety standards for cranes.

SET UP

1. Total rated loads shown on the TADANO LOAD RATING CHART are the maximum allowable crane capacities and are based on the machine standing level on firm supporting surface under ideal job conditions. Depending on the nature of the supporting surface, it may be necessary to have structural supports under the outrigger floats to spread the load to a larger bearing surface.
2. For on outrigger operation, outriggers shall be extended to the dimension according to the TADANO LOAD RATING CHART and secured by pins with tires free of supporting surface, before operating crane.

OPERATION

1. Total rated loads with outriggers fully extended do not exceed 85% of the tipping loads. Total rated loads with outriggers half extended are determined from the formula:
total rated load = (tipping load - 0,1 tip reaction) / 1.25.
2. The crane's structural steelwork is in accordance with DIN 15018, part 3. Design and construction of the crane comply with DIN 15018, part 2 and with F.E.M. regulations.
3. Total rated loads above the bold lines in the TADANO LOAD RATING CHART are based on crane strength and those below the bold lines on crane stability.
4. The weight of load handling devices such as hook blocks, slings, etc., must be considered as part of the load and must be deducted from lifting capacities.

Hookball / Hookblock (ton)	6.6	13.8	35				55				69.5			
No. of parts of line	1	2	3	4	5	6	7	8	10	12	13	14	15	
Max. lifting capacity (ton)	4.8	9.7	13.8	19.4	24.2	29.1	34	38.8	48.5	55	59.5	63	65	
Weight (lbs)	330	375	660				1,325				1,435			

5. Total rated loads are based on freely suspended loads and make no allowance for such factors as the effect of wind, sudden stopping of loads, supporting surface conditions, operating speeds, side loads, etc. Side pull on boom or jib is extremely dangerous.

6. Total rated loads do not account for wind on lifted load or boom. Total rated loads and boom length shall be appropriately reduced, when wind velocity is above 22 mph (32 ft/sec.).
7. Total rated loads at load radius shall not be exceeded. Do not tip the crane to determine allowable loads.
8. Do not operate at boom lengths beyond radius or boom angles where no capacities are shown. Crane may overturn without any load on the hook.
9. Slewing of the superstructure is admissible only when the crane is supported on half or fully extended outriggers.
10. The lifting capacity ratings specified in the TADANO LOAD RATING CHART apply to the telescopic boom without extendible fly jib fixed in transport position or working position. If the extendible fly jib is secured to the telescopic boom in transport position or working position, the lifting capacities of the telescopic boom are reduced by the values specified below. The weight of the extendible fly jib (2,200 lbs) is detected in terms of a load, and the load moment limiter will shut off earlier.
 - 29.5 ft / 52.5 ft. extendible fly jib, mounted in transport position
 - 29.5 ft. extendible fly jib, mounted to the boom head
 - 52.5 ft. extendible fly jib, mounted to the boom head
11. When making lifts at a load radius not shown, use the next longer radius to determine allowable capacity.
12. Load per part line should not exceed 10,050 lbs. for the main winch and for the auxiliary winch.
13. Loaded boom angles are approximate. The boom angle before loading should be greater to account for deflection.
14. The 34.1 ft boom length capacities are based on the telescopic boom being fully retracted. If not fully retracted (less than 58.5 ft boom length), use the total rated loads for the 58,5 ft boom length according to the telescoping sequence.
15. Extension or retraction of the telescopic boom with loads may be attempted within the limits of the TADANO LOAD RATING CHART. The ability to telescope loads is limited by hydraulic pressure, boom angle, boom length, crane maintenance, etc.
16. When erecting or stowing the extendible fly jib, be sure to retain it by hand or by other means to prevent its free movement.
17. Use the Anti-Two Block (OVERWIND CUTOUT) disable switch when erecting or stowing the extendible fly jib and stowing the hook block. While the switch is pushed, the hoist will not stop, even when an overwind condition occurs.
18. The working radius specified in the TADANO LOAD RATING CHARTS for the extendible fly jib apply only if the telescopic boom is extended according to the TADANO LOAD RATING CHARTS. If one or more elements of the telescopic boom are retracted partially or completely, the specified boom angles will be decisive in determining total rated lifting capacities.

19. When lifting a load by using the extendible fly jib (auxiliary hoist) and telescopic boom (main hoist) simultaneously, do the following:
- A. Select the correct program for the load moment device in accordance with jib length, jib offset angle, counterweight and outrigger base.
 - B. Before starting the operation, make sure that the weight of the load is within the total rated load for the extendible fly jib.
20. Safe Load Indicator (S.L.I.)
 Before working with the telescopic boom or extendible fly jib, make sure that the S.L.I. code is set according to the desired telescoping sequence while the telescopic boom is completely retracted. A change of the telescoping sequence is not permissible when the boom has been partially or fully extended. In order to change the S.L.I. code number, the boom must be fully retracted.
21. Working with Single Top
 Operation with the single top is allowed with the main winch and the auxiliary winch (2nd winch). The maximum allowed capacity is limited by the selected S.L.I. code for main boom operation according to existing counterweight and outrigger base at one side and by the single line pull which is limited by hydraulic pressure at the other side.
 For operations with the single top mounted, use the TADANO LOAD RATING CHART for the telescopic boom in accordance with existing counterweight and outrigger base to find the total rated lifting capacity and also select the correct S.L.I. code for the telescopic boom in accordance with the existing counterweight and outrigger base. Find the total rated lifting capacity based on boom length and working radius. From that value, subtract 1,100 lbs and the weights of all lifting equipment used including hook block, sling and other auxiliary lifting devices. The result (<total rated lifting capacity> - <1,100 lbs> - <lifting equipment>) is the total rated lifting capacity for a single top lift.

Definitions

1. Load Radius:
 Horizontal distance from a projection of the axis of rotation to supporting surface before loading to the center of the vertical hoist line or tackle with load applied. The deflection of the boom due to its deadweight and the rated load are taken into account.
2. Loaded Boom Angle:
 The angle between the boom base section and the horizontal, after lifting the total rated load at the working radius.
3. Working Area:
 Area measured in a circular arc about the centerline of rotation.
4. Freely Suspended Load:
 Load hanging free with no direct external force applied except by the hoist line.
5. Side Load:
 Horizontal side force applied to the lifted load either on the ground or in the air.

WARNING AND OPERATING INSTRUCTIONS FOR ON TIRE CAPACITIES

1. Total rated lifting capacities on tires are in pounds and do not exceed 75% of tipping loads as determined by test in accordance with SAE J-765.
2. Total rated lifting capacities shown in the TADANO LOAD RATING CHART are based on the condition that the crane is set on firm level supporting surfaces with suspension let down to block. Those above the bold lines are based on tire capacity and those below the bold lines on crane stability. They are based on actual load radius increased by tire deformation and boom deflection.
3. Total rated lifting capacities are based on proper tire inflation, capacity and condition. Damaged tires are hazardous to safe operation of the crane.
4. Tires shall be inflated to correct air pressure
 Tire Air Pressure
 14.00 R 25 - 145 psi (10 kgf/cm²)
 16.00 R 25 - 130 psi (9 kgf/cm²)
 20.5 R 25 - 100 psi (7 kgf/cm²)
5. On tire lifting with "extendible fly jib" is not permitted.
6. When making a lift on tires, set the parking brake.
7. Traveling with the load is permitted only if the following conditions exist:
 Machine is set on firm level supporting surface; tires inflated to specified pressure; boom must be centered over the rear of the machine; superstructure swing lock pin engaged; slewing brake engaged; maximum boom length not to exceed 58.5 ft; lifted load kept as close to the ground as possible and fastened to the chassis to prevent the lifted load from swinging or oscillating; travel slowly with a creeping speed not to exceed 1 mph; and especially avoid any abrupt steering, accelerating or braking.
 If possible, extend the outriggers and lower the outrigger floats to just above ground level.
8. Do not operate the crane while carrying the load.

Safe Load Indicator (PAT 350DS)

The Safe Load Indicator (PAT 350DS) is intended as an aid to the operator. Under no condition should it be relied upon to replace use of Load Rating Charts and Operating Instructions. Sole reliance upon the Safe Load Indicator Aids in place of good operating practice can cause an accident. The operator must exercise caution to assure safety.

