

BAY CRANE

www.baycrane.com

30 ton



Tadano TT300XL
Load Charts

TT-300XL

30 Ton Capacity (27.2 Metric Tons)

HYDRAULIC TRUCK CRANE

DIMENSIONS

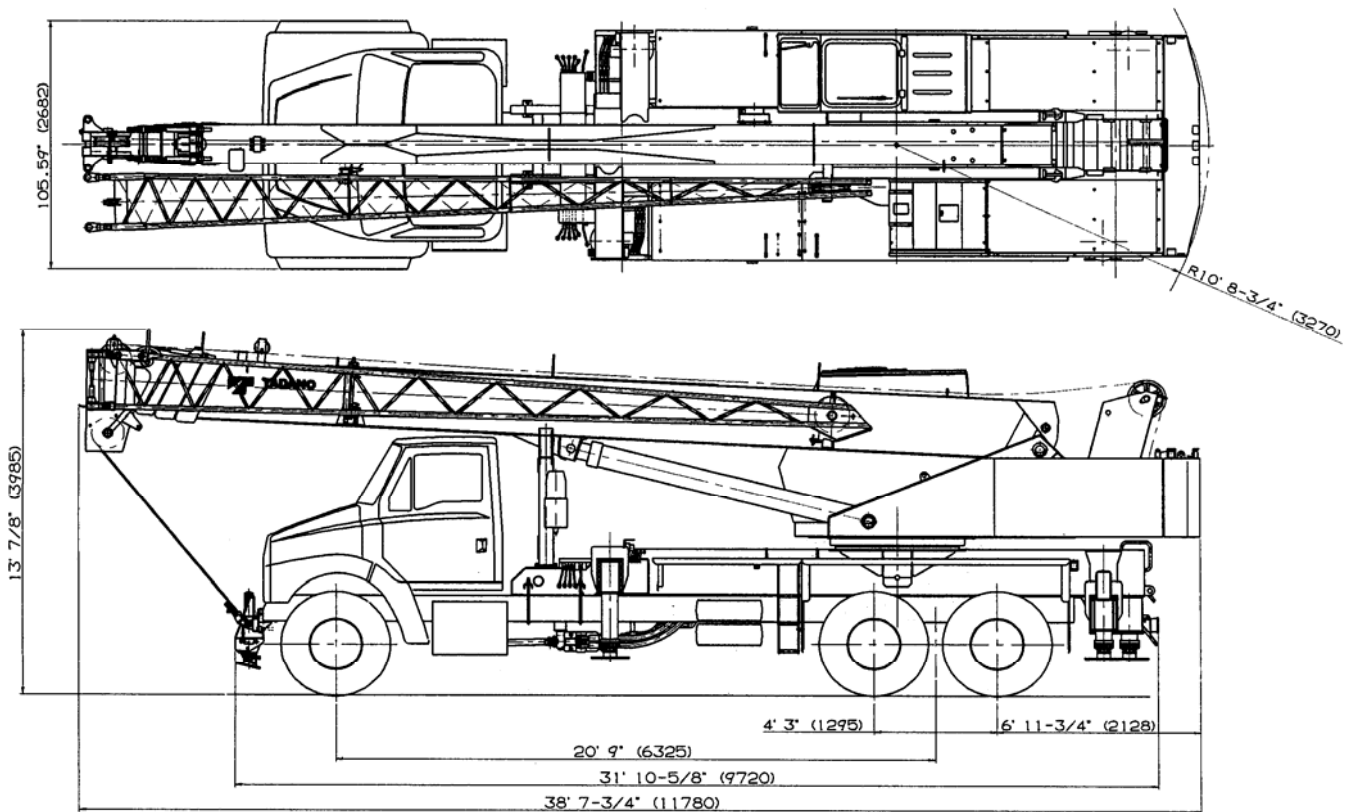

GENERAL DIMENSIONS

	Feet	Meters
Turning radius		
Front tire (curb to curb)	33.7'	10.3
Tail swing of counterweight	10' 8"	3.25

TRAVELING

Max. traveling speed 80.8mph (130km/h)

Specifications are subject to change without notice.

CRANE SPECIFICATIONS

BOOM

Four section full power synchronized telescoping boom, 32.2'-101.7' (9.8m-31m), of round hexagonal box construction with 4 sheaves, 12.9" (0.328m) pitch diameter, at boom head. The synchronization system consists of two-telescope cylinders, an extension cable and retraction cable. Hydraulic cylinder fitted with holding valve. Boom telescope sections are supported by wear pads both vertically and horizontally.

BOOM ELEVATION - By a double acting hydraulic cylinder with holding valve. Elevation -3°-80°.

JIB - Lattice type, 5° or 30° offset (tilt type). Single sheave, 14.2"(0.360m) pitch diameter, at jib head. Stored alongside base boom section. Jib length is 26.2' (8.0m).

ANTI-TWO BLOCK - Pendant type over-winding cut out device with audio-visual (FAILURE lamp/BUZZER) warning system.

SWING

Hydraulic axial piston motor driven through planetary swing speed reducer. Continuous 360° full circle swing on ball bearing turntable at 2.4rpm. Equipped with manually locked/released swing brake. Twin swing System: Free swing or lock swing controlled by selector switch on right hand of side console.

HOIST

MAIN HOIST - Hydraulic axial piston motor through winch speed reducer. Power load lowering and raising. Equipped with automatic brake (neutral brake) and counterbalance valve. Equipped with cable follower and drum rotation indicator.

DRUM - Grooved 12-5/8"(0.32m) root diameter x 21"(0.535m) wide. Wire rope: 558' of 5/8"diameter rope (170m of 16mm). Drum capacity: 796' (242.6m) 6 layers. Maximum line pull (permissible): 10,530lbs. (4,776kg)*. Maximum line speed: 406FPM (124m/min).

* Maximum permissible line pull may be affected by wire rope strength.

HOOK BLOCKS

20 ton (18.1 metric ton) - 3 sheaves with swivel hook and safety latch, for 5/8"(16mm) wire rope. (OPTIONAL)
3.74 ton (3.4 metric ton) - Weighted hook with swivel and safety latch, for 5/8"(16mm) wire rope.

HYDRAULIC SYSTEM

PUMPS - Two variable piston pumps for crane functions. Tandem gear pump for swing and outriggers. Powered by carrier engine. Pump disconnect for crane is engaged/ disengaged by rocker switch from carrier cab.

HOISTING PERFORMANCE

LINE SPEEDS AND PULLS

Layer	Speed	Main hoist - 12-5/8" (0.32m) drum					
		Line speeds ²		Line pulls			
		F.P.M	m/min	Available ¹		Permissible ³	
				Lbs.	kgf	Lbs.	kgf
1st	High	285	87	12,400	5,620	10,500	4,770
2nd	High	311	95	11,300	5,110	9,600	4,340
3rd	High	334	102	10,300	4,690	8,800	3,980
4th	High	360	110	9,500	4,330	8,100	3,680
5th	High	383	117	8,900	4,020	7,500	3,420

¹ Developed by machinery with each layer of wire rope, but not based on rope strength or other limitation in machinery or equipment.

² Line speeds based only on hook block, not loaded.

³ Permissible line pull may be affected by wire rope strength.

CONTROL VALVES - Multiple valves actuated by pilot pressure with integral pressure relief valves

RESERVOIR - 92 gallon (300 lit.) capacity. External sight level gauge.

FILTRATION - 26 micron return filter, full flow with bypass protection, located inside of hydraulic reservoir. Accessible for easy replacement.

OIL COOLER - Air cooled fan type.

COUNTERWEIGHT

Pinned to superstructure frame.
3,970lbs.(1,800kg).

CAB AND CONTROLS

Right side, 1 man type, steel construction with sliding door access and safety glass windows opening at side. Foot operated controls: boom telescoping and engine throttle. Cab heater.

Dash-mounted cigarette lighter, front wiper switch, free swing / lock swing selector switch and ashtray.

Instruments - Hydraulic oil pressure is monitored and displayed on the AML-L display panel.

Tadano electronic LOAD MOMENT INDICATOR system (AML-L) including:

- Load radius / boom angle / tip height / swing range preset function
- Warning buzzer
- Boom angle / boom length / jib offset angle / load radius / rated lifting capacities / actual loads read out
- Ratio of actual load moment to rated load moment indication
- Working condition register switch
- External warning lamp

TADANO AML-L monitors outrigger extended length and automatically programs the corresponding "RATED LIFTING CAPACITIES" table.

2nd boom emergency / 3rd, top boom emergency telescoping switch. Correct jib status select switch. Side console includes roof wiper switch, emergency outrigger set up key switch.

NOTE: Each crane motion speed is based on unladen conditions.

DRUM WIRE ROPE CAPACITIES

Wire rope layer	Main drum grooved lagging			
	5/8" (16mm) wire rope			
	Rope per layer		Total wire rope	
	Feet	Meters	Feet	Meters
1	109.3	33.3	109.3	33.3
2	228.0	69.5	337.3	102.8
3	356.0	108.5	693.3	211.3
4	493.4	150.4	1186.7	361.7
5	640.1	195.1	1826.8	556.8

DRUM DIMENSIONS

	Inch	mm
Root diameter	12-5/8"	320
Length	21"	535
Flange diameter	20-1/2"	520

CARRIER SPECIFICATIONS

MANUFACTURER - STERLING TRUCKS

MODEL - LT7501

TYPE - Left hand steering, 6x4

FRAME - High tensile steel

TRANSMISSION - 10 forward and 3 reverse speeds

TRAVEL SPEEDS -

Gear step/Gear	Traveling speeds in mph / k.p.h
1 st gear	0-4.1(0-6.6)
2 nd gear	6.4(10.3)
3 rd gear	9.6(15.4)
4 th gear	13.0(20.9)
5 th gear	17.6(28.3)
6 th gear	23.8(38.3)
7 th gear	32.9(52.9)
8 th gear	44.1(71.0)
9 th gear	60.3(97.0)
10 th gear	80.8(130.0)
1 st Revers gear	0-4.3(6.9)
2 nd Revers gear	6.7(10.8)
3 rd Revers gear	27.2(43.7)

AXLES - Front: Full floating type, steering axle

Rear: Full floating type, driving axle with inter-wheel differential lock.

ENGINE (US EPA on High way)

Model	CAT C7
No. of cylinders	6
Combustion	4 cycle, turbo charged and inter cooled
BoreXStroke, in.(mm)	4.9' X 5.8' (125X147)
Displacement, cu. in (liters)	441 (7.2)
Air inlet heater	12 volt preheat
Air cleaner	Dry type, replaceable element
Oil filter	Full flow and bypass with replaceable element
Fuel filter	Spin-on type
Fuel tank, gal.(liters)	70 (264), left side of carrier
Cooling	Liquid pressurized, recirculating by-pass

STEERING - Dual-circuit hydraulic and mechanical steering
Tilt steering wheel

SUSPENSION - Front: Leaf springs. Rear: Air

BRAKE SYSTEMS - Service: Full air brakes on all wheels
ABS system.

TIRES - Front: 425/65R22.5 SingleX2 Rear: 11R22.5 Dual x 4

OUTRIGGERS - Four hydraulic, beam and jack outriggers.

Vertical jack cylinders equipped with integral holding valve. Each outrigger beam and jack is controlled independently from either side of carrier. Beams extend to 19' 3/8" (5.8 m) center-line and retract to within 8' 5" (2.48 m) overall width. Controls and sight bubble located on both side of carrier. Two outrigger extension lengths are provided with corresponding "RATED LIFTING CAPACITIES" for crane duty in confined areas

Mid. extension 12' 1-3/8"(3.69m) center to center

Max. extension 19' 3/8"(5.8m) center to center

Float size(Diameter 1' 3-1/2" (0.4m)

FRONT JACK - A fifth hydraulically operated outrigger jack

Mounted to the front frame of carrier. Hydraulic cylinder equippe with integral holding valve and steel float.

Float size(Diameter 10-1/4"(0.26m)

STANDARD EQUIPMENT

FOR SUPERSTRUCTURE

- Four section full power synchronized boom 32.2'~101.7' (9.8 m~31 m)
- 26.2' (8.0m) lattice jib (tilt type) with 5° or 30° pinned offsets.
- Main hoist with grooved drum, cable follower and 558' of 5/8" cable.
- Drum rotation indicator main hoist.
- Anti-Two block device (overwind cutout)
- Tadano electronic load moment indicator system (AML-L) including
 - Load radius / boom angle / tip height / swing range preset function
 - Warning buzzer
 - Boom angle / boom length / jib offset angle / load radius /rated lifting capacities / actual loads read out
 - Ratio of actual load moment to rated load moment indication
 - Working condition register switch
 - External warning lamp
- Outrigger extension length detector
- Tadano twin swing system
- Control pedals for boom telescoping
- Front windshield wiper
- Roof window wiper
- Cab floor mat
- Mirror for main hoist
- Cigarette lighter
- Electric fan in cab
- 3.74 ton (3.4 metric ton) hook with swivel
- Weighted hook storage compartment
- Hydraulic oil cooler
- Cab heater

FOR CARRIER

- CAT C7 turbo charged and inter cooled engine.
- Front tires 425/65R22.5
- Rear tires 11R22.5
- Anti-block system (ABS)
- Air dryer
- Injection of ether
- Front jack (Fifth jack)
- Windshield wiper and washer
- 3 point type seat belt
- Sun visor
- Tilt steering wheel
- Air suspension seat
- Tachometer
- Hourmeter
- Engine temperature indicator
- Fuel level indicator
- Speedometer
- Reversing signal (Back-up alarm)
- High-beam light
- Hazard warning system
- Electric horn
- Hot water cab heater with defroster
- FM/AM radio
- Hook block tie down front bumper
- Air conditioner

OPTIONAL EQUIPMENT

- 20 ton (18.1 metric ton) 3 sheaves hook block

TT-300XL WORKING RANGE CHART

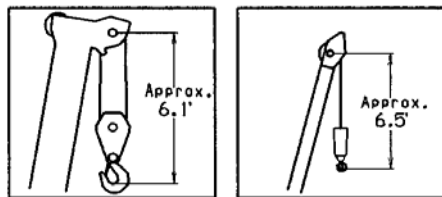
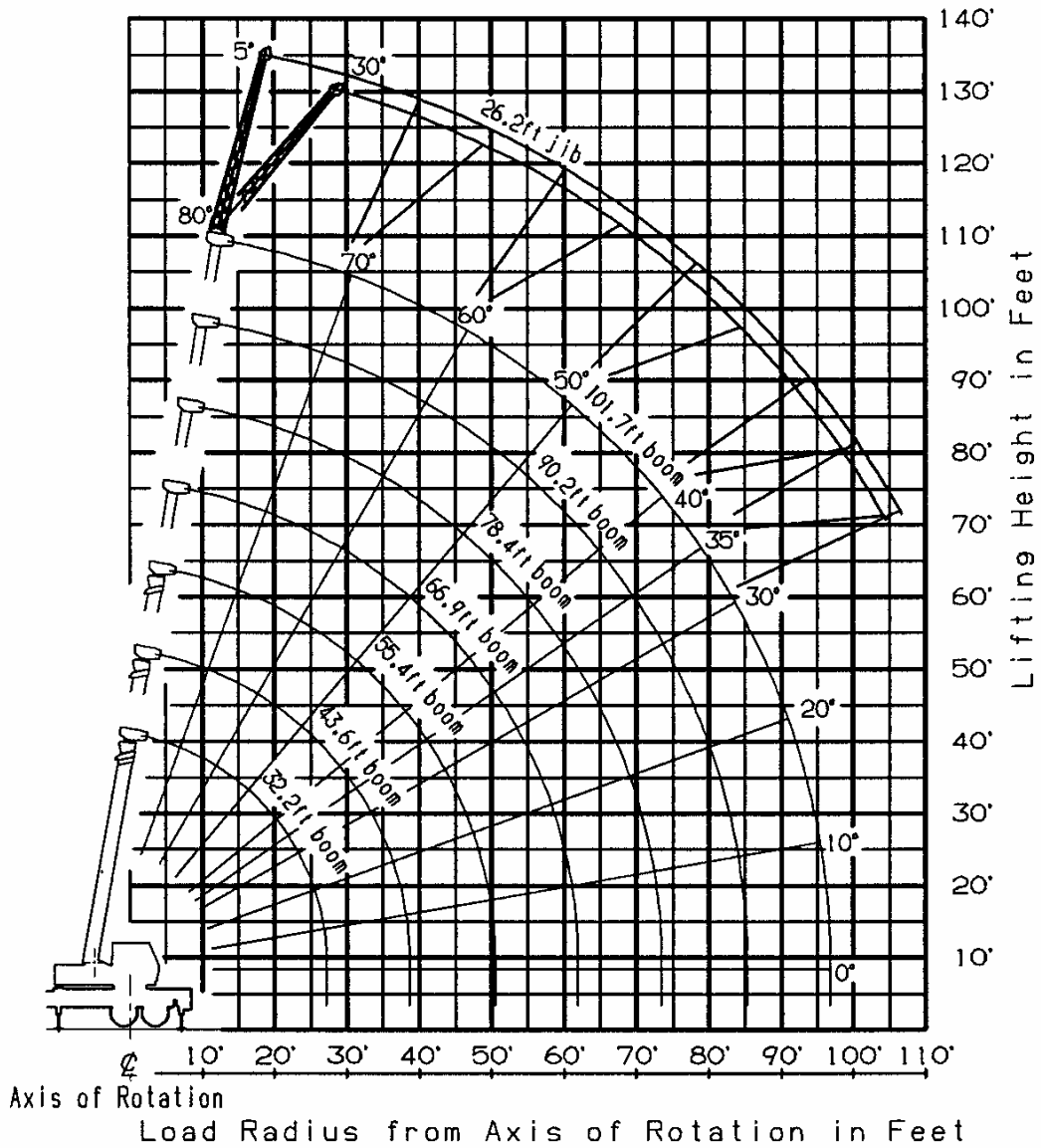

NOTE Boom and jib geometry shown are for unloaded condition and machine standing level on firm supporting surface. Boom deflection and subsequent radius and boom angle change must be accounted for when applying load to hook.

BOOM LENGTH

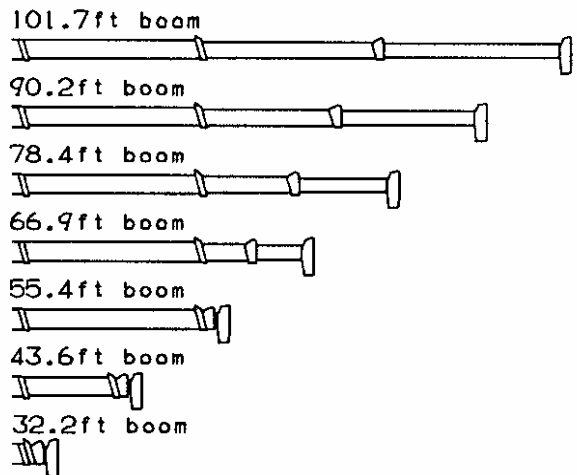

TT-300XL RATED LIFTING CAPACITIES (IN POUNDS)

ON OUTRIGGERS FULLY EXTENDED 19' 3/8" (5.8m) SPREAD, WITH FRONT JACK EXTENDED, 360° ROTATION																								
Boom length in feet												D		26.2ft (8.0m) JIB										
A	32.2		43.6		55.4		66.9		78.4		90.2			101.7		5° Tilt		30° Tilt						
	B	(9.8m)	B	(13.3m)	B	(16.9m)	B	(20.4m)	B	(23.9m)	B			(27.5m)	B	(31m)	R	W	R	W				
8	69	60,000	75	38,600	78	32,000									80°	22	6,060	32	2,980					
10	65	55,100	72	38,600	76	32,000	79	20,900							75°	35	6,060	43	2,980					
12	61	43,300	69	38,600	74	32,000	77	20,900	79	16,500					70°	46	5,070	54	2,870					
15	54	35,400	65	34,400	71	31,500	74	20,900	77	16,500	79	14,300			65°	56	4,410	64	2,760					
20	42	26,600	58	26,400	65	24,500	70	20,900	74	16,500	76	14,300	78	13,200	60°	66	3,530	72	2,650					
25	24	20,300	49	19,900	59	19,700	65	18,200	70	16,400	73	14,200	76	13,100	55°	75	2,870	81	2,200					
30			39	15,500	53	15,300	60	15,200	66	14,500	70	12,500	73	11,300	50°	83	2,310	89	1,870					
35					46	11,800	55	12,300	62	12,700	66	11,100	70	9,850	45°	91	1,650	96	1,540					
40					38	8,840	50	9,590	57	10,100	63	9,740	67	8,710	40°	98	1,210	102	1,100					
45					29	6,900	44	7,560	53	8,020	59	8,310	64	7,870	35°	104	880	107	770					
50							37	6,060	48	6,440	55	6,860	60	6,830	30°	110	550							
55							29	4,830	42	5,290	51	5,560	57	5,800										
60									36	4,340	46	4,590	53	4,920										
65									29	3,510	41	3,840	49	4,060										
70									19	2,800	36	3,130	45	3,350										
75											30	2,580	41	2,780										
80													36	2,310										
85													30	1,900										
90													24	1,480										
C	0°																							

ON OUTRIGGERS MID EXTENDED 12' 1-3/8" (3.69m) SPREAD, WITH FRONT JACK EXTENDED, 360° ROTATION																					
Boom length in feet												D		26.2ft (8.0m) JIB							
A	32.2		43.6		55.4		66.9		78.4		90.2			101.7		5° Tilt		30° Tilt			
	B	(9.8m)	B	(13.3m)	B	(16.9m)	B	(20.4m)	B	(23.9m)	B			(27.5m)	B	(31m)	R	W	R	W	
8	69	60,000	75	38,600	78	32,000									80°	22	6,060	32	2,980		
10	65	55,100	72	38,600	76	32,000	79	20,900							75°	35	6,060	43	2,980		
12	61	43,300	69	38,600	74	32,000	77	20,900	79	16,500					70°	46	4,540	54	2,870		
15	54	28,800	65	28,200	71	27,600	75	20,900	77	16,500	79	14,300			65°	55	2,780	63	2,360		
20	42	16,500	57	16,200	65	15,900	70	16,700	74	16,500	76	14,300	78	13,200	60°	65	1,680	71	1,460		
25	24	10,900	49	10,400	59	10,400	65	11,100	70	11,600	73	11,900	75	12,100	55°	73	900	80	820		
30			39	7,240	53	7,120	60	7,870	66	8,270	69	8,550	72	8,750							
35					46	4,850	55	5,640	61	6,110	66	6,370	69	6,570							
40					38	3,260	50	3,930	57	4,480	62	4,810	66	5,030							
45					28	2,050	44	2,720	52	3,240	58	3,570	63	3,790							
50							37	1,780	47	2,250	54	2,620	59	2,840							
55							28	1,080	42	1,490	50	1,840	56	2,030							
60											46	1,210	52	1,400							
C	0°			22°			37°			42°			48°								

A :Load radius in feet

B :Boom angle (°)

C :Minimum boom angle for indicated length(no load)

D :Boom angle in degree

R :Load radius (ft)

W :Rated lifting capacity in pounds

WARNING AND OPERATING INSTRUCTIONS FOR LIFTING CAPACITIES

GENERAL

1. RATED LIFTING CAPACITIES apply only to the machine as originally manufactured and normally equipped by TADANO LTD.
Modifications to the machine or use of optional equipment other than that specified can result in a reduction of capacity
2. Hydraulic cranes can be hazardous if improperly operated or maintained. Operation and maintenance of the machine must be in compliance with information in the **Operation and Maintenance Manual** supplied with machine. If these manuals are missing, order replacement through the distributor.
3. The operator and other personnel associated with the machine shall fully acquaint themselves with the latest American National Standards Institute (ANSI) safety standards for cranes.

SET UP

1. Rated lifting capacities on the chart are the maximum allowable crane capacities and are based on the machine standing level on firm supporting surface under ideal job conditions. Depending on the nature of the supporting surface, it may be necessary to have structural support under the outrigger floats to spread the loads to a large bearing surface.
2. For outrigger operation, outriggers shall be properly extended with tires free of supporting surface before operating crane. The front jack must be properly extended.

OPERATION

1. Rated lifting capacities have been tested to and meet minimum requirements of SAE J1063-Cantilevered Boom Crane Structures Method of Test.
2. Rated lifting capacities do not exceed 85% of the tipping load on outriggers fully extended as determined by SAE J765-Crane Stability Test Code.
Rated lifting capacities for partially extended outriggers are determined from the formula, Rated Lifting Capacities = (Tipping Load - 0.1 x Tip Reaction) / 1.25.
3. Rated lifting capacities above bold lines in the chart are based on crane strength and those below, on its stability. They are based on actual load radius increased by boom deflection.
4. The weight of handling device such as hook blocks, slings, etc., must be considered as part of the load and must be deducted from the lifting capacities.
5. Rated lifting capacities are based on freely suspended loads and make no allowance for such factors as the effect of wind, sudden stopping of loads, supporting surface conditions, operating speeds, side loads, etc. Side pull on boom or jib is extremely dangerous.
6. Rated lifting capacities do not account for wind on lifted load or boom. Rated lifting capacities and boom length shall be appropriately reduced, when wind velocity exceeds 20 mph (9 m/sec.).
7. Rated lifting capacities at load radius shall not be exceeded. Do not tip the crane to determine allowable loads.
8. Do not operate at boom lengths, radii, or boom angle, when no capacities are shown. Crane may overturn without any load on the hook.
9. When boom length is between values listed, refer to the rated lifting capacities of the next longer and next shorter booms for the same radius. The lesser of the two rated lifting capacities shall be used.

10. When making lifts at a load radius not shown, use the next longer radius to determine allowable capacity.
11. Load per line should not exceed 7,496 lbs. (3,400kg) for main winch.
12. Check the actual number of parts of line with LOAD MOMENT INDICATOR (AML-L) before operation. Maximum lifting capacity is restricted by the number of parts of line of LOAD MOMENT INDICATOR (AML-L). Limited capacity is as determined from the formula, Single line pull for main winch (7,496 lbs.) x number of parts of line.
13. The boom angle before loading should be greater to account for deflection. For rated lifting capacities, the loaded boom angle and the load radius is for reference only.
14. The 32.2' (9.8m) boom length capacities are based on boom fully retracted. If not fully retracted [less than 43.6' (16.8m) boom length], use the rated lifting capacities for the 43.6' (16.8m) boom length.
15. Extension or retraction of the boom with loads may be attempted within the limits of the RATED LIFTING CAPACITIES. The ability to telescope loads is limited by hydraulic pressure boom angle, boom length, crane maintenance, etc.
16. For lifting capacity of single top, reduce the rated lifting capacities of relevant boom according to a weight reduction for auxiliary load handling equipment.
17. When erecting and stowing jib, be sure to retain it by hand or by other means to prevent its free movement.
18. Use "ANTI-TWO BLOCK" disable switch when erecting and stowing jib and when stowing hook block. While the switch pushed, the hoist does not stop, even when overwind condition occurs.
19. For boom length with 26.2' (8m) jib, rated lifting capacities are determined by loaded boom angle only in the column headed "101.7' (31m) boom + 26.2' (8m) jib".
For angles not shown, use the next lower loaded boom angle to determine allowable capacity.

DEFINITIONS

1. Load Radius: Horizontal distance from a projection of the axis of rotation to supporting surface before loading to the center the vertical hoist line or tackle with load applied.
2. Loaded Boom Angle: The angle between the boom base section and the horizontal, after lifting the rated lifting capacity at the load radius.
3. Working Area: Area measured in a circular arc about the centerline of rotation.
4. Freely Suspended Load: Load hanging free with no direct external force applied except by the hoist line.
5. Side Load: Horizontal side force applied to the lifted load either on the ground or in the air.

WARNING AND OPERATING INSTRUCTIONS FOR USING THE LOAD MOMENT INDICATOR (AML-L)

- When operating crane on outriggers:
 - Set Starter switch to "ON" .
 - Press the outrigger mode select key to register for the outrigger operation. Press the set key, then the outrigger mode indicative symbol changes from flickering to lighting.
 - Press the boom mode select key to register the boom mode, then the boom mode indicative symbol changes from lighting to flickering. Each time the boom mode select key is pressed, the mode changes. Press the set key to select the status that corresponds to the actual state of the boom, then the boom mode indicative symbol changes from flickering to lighting.
 - When erecting and stowing jib, select the status of jib set (jib state indicative symbol flicker).
- During crane operation, make sure that the displays on from panel are in accordance with actual operating conditions.
- The displayed values of LOAD MOMENT INDICATOR (AML-L) are based on freely suspended loads and make no allowance for such factors as the effect of wind, sudden stopping of loads, supporting surface conditions, operating speed, side loads, etc.
For safe operation, it is recommended when extending and lowering boom or swinging, lifting loads shall be appropriately reduced.
- LOAD MOMENT INDICATOR (AML-L) is intended as an aid to the operator. Under no condition should it be relied upon to replace use of capacity charts and operating instruction. Sole reliance upon LOAD MOMENT INDICATOR (AML-L) aids in place of good operating practice can cause an accident. The operator must exercise caution to assure safety.

TT-300XL Axle weight distribution chart

	Pounds			Kilograms		
	GVW	Front	Rear	GVW	Front	Rear
Base machine with 70gal.(265L) fuel and counterweight.	55,400	16,140	39,260	25,130	7,320	17,810
Add: 1. 20 ton (18.1 metric ton) 3 sheaves hook block	550	710	-160	250	322	-72

Permissible Axle Load

	Pounds			Kilograms		
	GVW	Front	Rear	GVW	Front	Rear
Permissible axle load	66,000	20,000	46,000	29,900	9,000	20,900

MEMO

TADANO AMERICA CORPORATION

333 NORTHPARK CENTRAL DRIVE, SUITE Z,
HOUSTON, TEXAS 77073, U.S.A.

PHONE: (281) 869-0030 EXT.315

FAX: (281) 869-0040

Web site: www.tadano-cranes.com/

E-mail: sales@tadano-cranes.com

Form No. TAC-TT-300-1-060630